

INSTALLATION INSTRUCTIONS

A. Unpacking

1. Carefully remove crate from the skid.
2. Remove machine from skid.
3. Wipe down outside of the machine.
4. Clean inside of the drum (use the bolts on the end of the frame to hold the drum cover when not on the drum).
5. Check aim of photo-eyes (see instructions in trouble-shooting section)-this is required due to vibration in shipping.

B. Checking Control Panel

1. Check inside the cabinet for the required voltage requirement for your machine. Plug the machine into the required outlet.
2. Press the (RST/ENT) button on the tumbler timer.
3. Check photo-eyes for power (The red light on the back side of the photo-eye should be on. This can be see through the observation windows near each photo eye. The light on both photo-eyes must be on. If they are not, wipe the face of the photo eye and the reflectors opposite them to remove all moisture. If still not on see instructions for checking aim of the photo-eyes).

C. Check Vacuum Pump Control

1. Press the vacuum start button. It should run.

D. Check Tumbler Motor Controls

1. Set variable speed control to 20.
2. Set tumbler timer to 2 minutes.(See "SETTING THE CONTROL TIMER" in the Operating Instructions Section).
3. Set continuous-forward-reverse jog switch to continuous.
4. Press the tumbler start button - drum will now turn.
5. Turn the variable speed control up & down (drum will speed up & slow down).
6. The drum will turn until the tumbler timer counts down to zero at which time the drum will stop.
7. Press the (RST/ENT) button on the tumbler timer.
8. The machine is now ready to use.

E. Check Forward & Reverse Jog (useful for unloading the drum)

1. Set variable speed control to a slow speed setting (0-10).
2. Set continuous-forward-reverse jog switch to reverse.
3. Press and hold the start button. The drum will turn only while the start button is being held in.
4. Repeat steps 2 & 3 for forward jog.

OPERATING INSTRUCTIONS

A. Loading and Tumbling

1. Clean the machine drum.
2. Put the gasket and drain cap on the drum drain pipe.
3. Load the product into the drum.
4. Place the gasket over the drum opening.
5. Place the cover on the gasket.
6. Make sure the gasket is under the cover all the way around by pushing it up and into the opening or by visual inspection.
7. Tighten the cover by alternately tightening the knob in a diagonal pattern.
8. Plug the machine into the proper voltage receptacle.
9. Check for power to the photo-eyes through observation windows (Red light should be on. If they are not on wipe the photo-eye face and reflector to remove moisture).
10. Turn on vacuum pump.
11. Open vacuum valve on the drum (next to the drum cover) (Make sure the vacuum passage to the drum is clean and that it is to the top. Pulling vacuum with the fitting not at the top position will result in liquid being drawn into the vacuum pump. **THIS WILL DAMAGE THE PUMP!**)
12. Push vacuum hose onto drum fitting.
13. Run vacuum pump until 15 inches of vacuum is drawn (Higher vacuum can be drawn if you want to).
14. Shut off the valve on the drum.
15. Remove the hose.
16. Turn off the vacuum pump.
17. Set the tumbler timer to the desired time.
18. Set variable speed knob to the desired speed.
19. Set the continuous-forward-reverse jog switch to continuous.
20. Make sure the vacuum hose is disconnected.
21. Press tumbler start button. The drum will now rotate until the tumbler timer runs down to zero.
 - * It can be stopped at any time by pressing the tumbler stop button or by breaking the beam from the photo-eye to the reflector.
 - * To restart the machine, press the tumbler start button, it will run for the time remaining on the timer.

B. Unloading the Drum

a. Manual Unloading

1. Set the Continuous-Forward-Reverse Jog switch to forward.
2. Press and hold the tumbler start button until the cover is facing you, at the 2 O'clock position.
3. Loosen the cover knobs.

4. Open the vacuum valve on the drum to release the vacuum (Loosen cover knobs first).
5. Remove the cover.
6. Remove the gasket.
7. Unload the drum.

b. Unloading into a buggy or cart

1. Set the Continuous-Forward-Reverse Jog switch to forward.
2. Press and hold the tumbler start button until the cover is facing you, at the 2 o'clock position.
3. Loosen the cover knobs.
4. Open the vacuum valve on the drum to release the vacuum (Loosen cover knobs first).
5. Remove the cover.
6. Remove the gasket.
7. Tighten the cover knobs so you don't lose them while unloading.
8. Place the cart under the drum.
9. Press and hold the tumbler start button until the product starts to roll out of the drum opening.
10. Release the tumbler start button when the product starts to roll out, press again if necessary.
11. To reverse the drum to stop unloading, set the continuous-forward-reverse switch to reverse, press and hold tumbler button until the product stops coming out of the drum.
12. To continue unloading set the continuous-forward-reverse jog switch to forward.
13. Repeat steps 9 - 11.

LT30 OR LT60 CONTROL PANEL WITH ELECTRONIC TUMBLER TIMER

CONTROL PANEL FUNCTION

TUMBLER PUSH BUTTONS

Starts and stops timers for the tumbling cycle.

VACUUM PUSH BUTTONS

Starts and stops vacuum pump.

TOTAL TIMER

Sets the total amount of time the drum will rotate.

SETTING THE CONTROL TIMER

Direct start continuous tumbling:

1. Press (RST/ENT) button on the tumbler timer.
2. Set the set point on the tumbler timer for total tumbling time (time required for the drum to rotate.)
3. To set the time on the tumbler timer press the (PR) button.
4. Notice the number that is flashing, press the button with the arrow pointing to right to the desired position you want to change (the timer is set for hour-min.).
5. Press the button with the arrow pointing up to set the desired time (each position has to be done separately).
6. After the time is set press the (RST/ENT) button to enter the time.
7. Press the (RST/ENT) again to change the current time on the timer.
8. The tumbler timer is ready to run.
9. Press the tumbler start button to begin the cycle.

Stopping the tumbler with tumbler STOP button or photo-eye switch will stop the tumbler timer and maintain it's time.

Pressing the tumbler START button will restart the tumbler timer from where it left off. Pressing the reset button on the tumbler timer in the middle of a tumbling cycle will reset that timer to the preset time settings.

LT30 or LT60
CONTROL PANEL WITH ELECTRONIC INTERVAL TIMER AND TUMBLER TIMER

CONTROL PANEL FUNCTION

TUMBLER PUSH BUTTONS

Starts and stops timers for the tumbling cycle.

VACUUM PUSH BUTTONS

Starts and stops vacuum pump.

TOTAL TIMER

Sets the total amount of time the drum will rotate. During the intermittent tumbling cycle, this timer runs only during the on period of the cycle.

INTERMITTENT TIMER

Set point 1 "TON" sets amount of time drum rotates during on cycle.

Set point 2 "TOFF" sets amount of time drum rests during off cycle.

SETTING THE CONTROL TIMER

Direct start continuous tumbling:

1. Press (RST/ENT) button on the tumbler timer.
2. Set the set point on the tumbler timer for total tumbling time (time required for the drum to rotate).
3. To set the time on the tumbler timer press the (PR) button.
4. Notice the number that is flashing, press the button with the arrow pointing to right to the desired position you want to change (the timer is set for hour-min.).
5. Press the button with the arrow pointing up to set the desired time (each position has to be done separately).
6. After the time is set press the (RST/ENT) button to enter the time.
7. Press the (RST/ENT) again to change the current time on the timer.
8. The tumbler timer is ready to run.
9. Press (RST/ENT) button on the interval timer.
10. Set, set point 1 "TON" to a time greater than was set on the tumbler timer.
11. To set the "TON" time on the interval timer press the (PR) button.
12. Notice the "TON" in the lower left corner of the timer is for the on time.
13. Notice the number that is flashing, press the button with the arrow pointing to the right to the desired position you want to change (the timer is set for hour-min.).
14. Press the button with the arrow pointing up to set the desired time (each position is done separately). Set this time higher than what was set on the tumbler timer.
15. After the time is set press the (RST/ENT) button to enter the time.
16. Set, set point 2 "TOFF" to 1 min.
17. To set the "TOFF" time on the interval timer press the (PR) button twice.
18. Notice the "TOFF" in the lower left corner of the timer is for the off time.
19. Notice the number that is flashing, press the button with the arrow pointing to the right to desired position you want to change (the timer is set for hour-min.).
20. Press the button with the arrow pointing up to set the desired time (each position is done separately). Set this time for 1 min.

21. After the time is set press the (RST/ENT) button to enter the time.
22. Notice the timer will now display "TON" time.
23. The Interval timer is now ready to run.
24. Press the tumbler start button to begin the cycle.

Direct start intermittent tumbling:

1. Press (RST/ENT) button on the tumbler timer.
2. Set the set point on the tumbler timer for total tumbling time (time required for the drum to rotate).
3. To set the time on the tumbler timer press the (PR) button.
4. Notice the number that is flashing, press the button with the arrow pointing to right to the desired position you want to change (the timer is set for hour-min.).
5. Press the button with the arrow pointing up to set the desired time (each position has to be done separately).
6. After the time is set press the (RST/ENT) button to enter the time.
7. Press the (RST/ENT) again to change the current time on the timer.
8. The tumbler timer is ready to run.
9. Press (RST/ENT) button on the interval timer.
10. Set, set point 1 "TON" for the amount of time you want the tumbler to run during it's on cycle. (The on cycle will start first).
11. To set the "TON" time on the interval timer press the (PR) button.
12. Notice the "TON" in the lower left corner of the timer is for the on time.
13. Notice the number that is flashing, press the button with the arrow pointing to the right to the desired position you want to change (the timer is set for hour-min.).
14. Press the button with the arrow pointing up to set the desired on time (each position is done separately).
15. After the time is set press the (RST/ENT) button to enter the time.
16. Set, set point 2 "TOFF" for the amount of time you want the tumble to rest during it's off cycle.
17. To set the "TOFF" time on the interval timer press the (PR) button twice.
18. Notice the "TOFF" in the lower left corner of the timer is for the off time.
19. Notice the number that is flashing, press the button with the arrow pointing to the right to desired position you want to change (the timer is set for hour-min.).
20. Press the button with the arrow pointing up to set the desired off time (each position is done separately).
21. After the time is set press the (RST/ENT) button to enter the time.
22. Notice the timer will now display "TON" time.
23. The Interval timer is now ready to run.
24. Press the tumbler start button to begin the cycle.

During the continuous or intermittent timing cycle the tumbler timer will only count down when the ON cycle is timing on the intermittent timer. Stopping the tumbler with tumbler STOP button or photo-eye switch will stop the tumbler timer and maintain it's time. The intermittent timer will reset to the preset times. Pressing the tumbler START button will restart the intermittent timer. The total timer will restart from where it left off. Pressing the reset button on either the tumbler timer or interval timer in the middle of a tumbling cycle will reset that timer to the preset time settings.

CLEANING PRECAUTIONS

Do not clean photo-eyes and reflectors with abrasive material, this could damage the components.

Do not spray water directly at the control panel, it could damage the components. Use a damp rag to clean the control panel face.

If the knob on the timer begins to turn hard, remove the black knob by loosening the set screw on the knob. Loosen the nut under the black knob.

CLEANING YOUR MACHINE

Fill your machine so warm water goes to top of paddle. Using your standard cleaning solution, put in ½ to 1 cup, depending on the strength. Turn machine on and agitate for ten to fifteen minutes. When you stop the machine, make sure the drain plug is on top. Remove the plug and turn the machine on until drain is at the bottom. Remove lid and rinse. (**CAUTION: Extremely hot water will cause fat to bake on walls.**) Wipe off safety eyes and reflectors after cleaning.

FLUSHING VACUUM VALVE ON DRUM

Open vacuum valve and thoroughly flush with water. This must be done between loads, before pulling vacuum on the drum. If valve is not cleaned properly, food particles will be drawn into the vacuum hose.

CLEANING VACUUM HOSE

To clean food particles from the vacuum hose, remove glass jar (located inside cabinet) from the filter, and flush water through hose. Clean glass jar before replacing.

EMERGENCY STOP PHOTO-EYES

These are installed for your protection! When the sensor beam is broken, the machine is automatically shut off. If the machine does not want to start, it is possible either the reflector or sensor eyes are dirty or wet. If you do have a problem with the sensor, it is quickly identified by a red light located on the back of the sensor. Check for power to the photo-eyes through observation window. (Red light should be on, if they are not on wipe the photo-eye face and reflector to remove moisture.)

RECOMMENDED PROCEDURES FOR TUMBLING PRODUCT

<u>PRODUCT & INSTRUCTION</u>	<u>% OF BRINE GREEN WT.</u>	<u>TOTAL TIME</u>	<u>MOTOR DRUM LOAD</u>	<u>SPEED</u>
<u>Dried Beef</u>				
Pump product with normal or recommended % of brine. Put product and excess purge into tumbler.	10%	3 hrs. 2.5 hrs.	½ or more ½ or less	4
<u>Beef Jerky</u>				
Get total weight of sliced product to verify % of brine to be added	10%	25 min. 15 min.	½ or more ½ or less	4
<u>Chunked & Formed</u>				
Using Ham Meat and Boston Butt parts (90%lean), run product through kidney plate on grinder. Get total weight to verify % of brine to be added. Tumble for stated period of time. Remove from tumbler. Run product through stuffer into large casing. Put into ham press and smoke under normal smoking conditions.	10%	1 hr.		7
<u>Chicken</u>				
After obtaining total weight of birds, add normal or recommended % of brine and tumble product and brine for required time.	10%	1 hr.	½ or more	4
<u>Turkey</u>				
Obtain total weight of birds. Pump breast, leg and wings on both sides with normal or recommended % of brine. Put product and excess purge in tumbler for recommended time. Then follow normal smoking procedures.	10%	1 hr.	½ or more	6

<u>Bone-In Ham</u>				
Pump your normal or recommended % of brine per green weight and put product and excess purge in tumbler.	15%	3.5 hrs. 3 hrs.	½ or more ½ or less	6
<u>Boneless Ham</u>				
Same process as Bone-In	15%	3 hrs. 2.5 hrs.	½ or more ½ or less	5
<u>Bacon</u>				
Obtain total weight of all product. Using your normal or recommended % of brine per green weight, put bellies and brine into tumbler	10%	3 hrs. 2.5 hrs.	½ or more ½ or less	5
<u>Cottage Bacon</u>				
Pump product with normal or recommended % of brine per green weight. Put product and excess purge into tumbler.	10%	3 hrs. 2.5 hrs	½ or more ½ or less	5
<u>Pork Ribs</u>				
Get total weight of the product to verify % of brine to be added.	10%	.5 hrs.		4
<u>Pork Hocks</u>				
Get total weight of the product to verify % of brine to be added.	15%	2 hrs. 1.5 hrs.	½ or more ½ or less	4
<u>Beef or Pork Roast</u>				
Pump roasts with normal or recommended soluble roast spice.	10%	4 hrs. 3.5 hrs.	½ or more ½ or less	4

* After tumbling put into cooking bag and bring internal temperature to 150 degrees. Product is now ready for sale.

MAINTENANCE

WARNING: DISCONNECT POWER BEFORE SERVICING.

NOTE: Lock and tag power disconnect to prevent application of power.

CLEANING

Properly selected and installed electric motors are capable of operating for long periods with minimal maintenance. Periodically clean dirt accumulations from open-type motors, especially in and around vent openings, preferably by vacuuming (avoid imbedding dirt in windings). At the same time check that electrical connections are tight.

LUBRICATION

The motor is equipped with pre-lubricated ball bearings and will not require re-lubrication. Should the gears or bearings require lubrication, use type "L-Industrial 30" (American Oil Co.) grease or its equivalent. The following is a list of lubricants which can be used: Mobile UX-EP2, Philube =EP2, Gulf Crown =EP2, Alvania =EP2, or Mutifax =EP2.

IMPORTANT: COMPLETELY CLEAN THE OLD LUBRICANT FROM THE GEAR BOX BEFORE ADDING FRESH LUBRICANT. UNDER NO CIRCUMSTANCES SHOULD DIFFERENT TYPES OF LUBRICANTS BE MIXED!

MAINTENANCE & LUBRICATION SCHEDULE

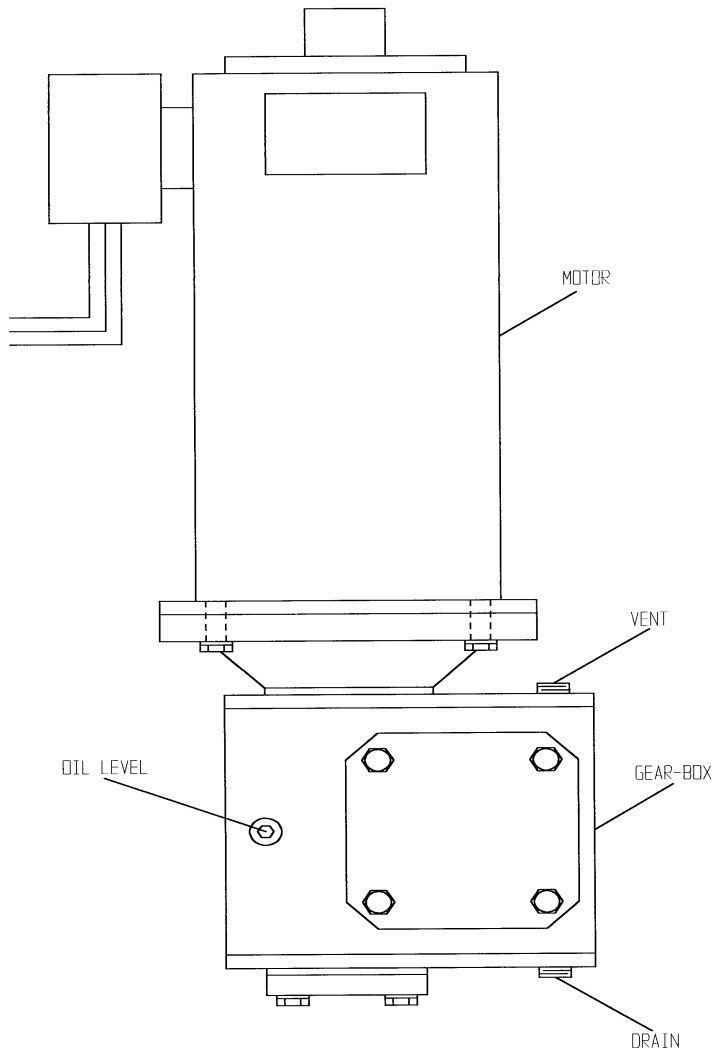

MOTOR BRUSHES

Motor brushes need period inspection and replacement as wear indicates. Brush wear is greatly influenced by individual application. It is recommended that brush wear be checked at intervals of operation in order to determine future required inspection. Standard LEESON brushes have an initial length of 1-1/4". When the brushes are worn to a length of 5/8" they should be replaced.

LUBRICATION

This motor is supplied with pre-lubricated ball bearings, lubricated for life of bearings.

GEAR BOX MAINTENANCE

Frequently check the oil level of the reducer. If the oil level is low add lubrication through filler plug until it comes out the oil level plug. Inspect vent plug often to insure it is clean and operating.

MANUFACTURER'S RECOMMENDED LUBRICANTS

MANUFACTURER	50-125 F AMBIENT TEMPERATURE AMGA Compounded No. 8
Amoco Oil Co.	Cylinder Oil #680
Chevron USA, Inc.	Cylinder Oil #680X
Exxon Co. USA	Cylesstic TK-680
Gulf Oil Co.	Senate 680D
Mobile Oil Corp.	Extra Hecla Super
Shell Oil Co.	Valvata Oil J680
Sun Oil Co.	Gear Oil 8C
Texaco	650T Cylinder Oil

CHECKING THE AIM OF A PHOTO-EYE

1. Press the (RST/ENT) button on the timer. This will supply power to the photo-eyes which will be indicated by a red light on at the back of the timer. (If they won't come on, the photo-eye might be out of alignment.)
2. Take a piece of masking tape and cover up the reflector. Only the one reflector that is opposite of the photo-eye that you are checking.
3. Use a reflector for checking the sensing range of the photo-eye. Take this reflector and hold it over the reflector that you taped up.
 - A. Move the reflector to the left until the red light on the photo-eye goes out, measure this distance (see Figure "A"), which we will call distance "A".
 - B. Move the reflector to the right until the red light on the photo-eye goes out, measure this distance (see Figure "A"), which we will call distance "B".
 - C. Move the reflector up until the red light on the photo-eye goes out, measure this distance (see Figure "A"), which we will call distance "C".
 - D. Move the reflector down until the red light on the photo-eye goes out, measure this distance (see Figure "A"), which we will call Distance "D".
4. Distance "A" & "B" should be about the same and "C" & "D" should be about the same. If measurement "A" & "B" are not equal and "C" & "D" are not equal the photo-eye aim needs to be adjusted (see **ADJUSTING THE AIM OF THE PHOTO-EYE**). If they are equal repeat this procedure on the second photo-eye (Model LT30 and LT60 only).

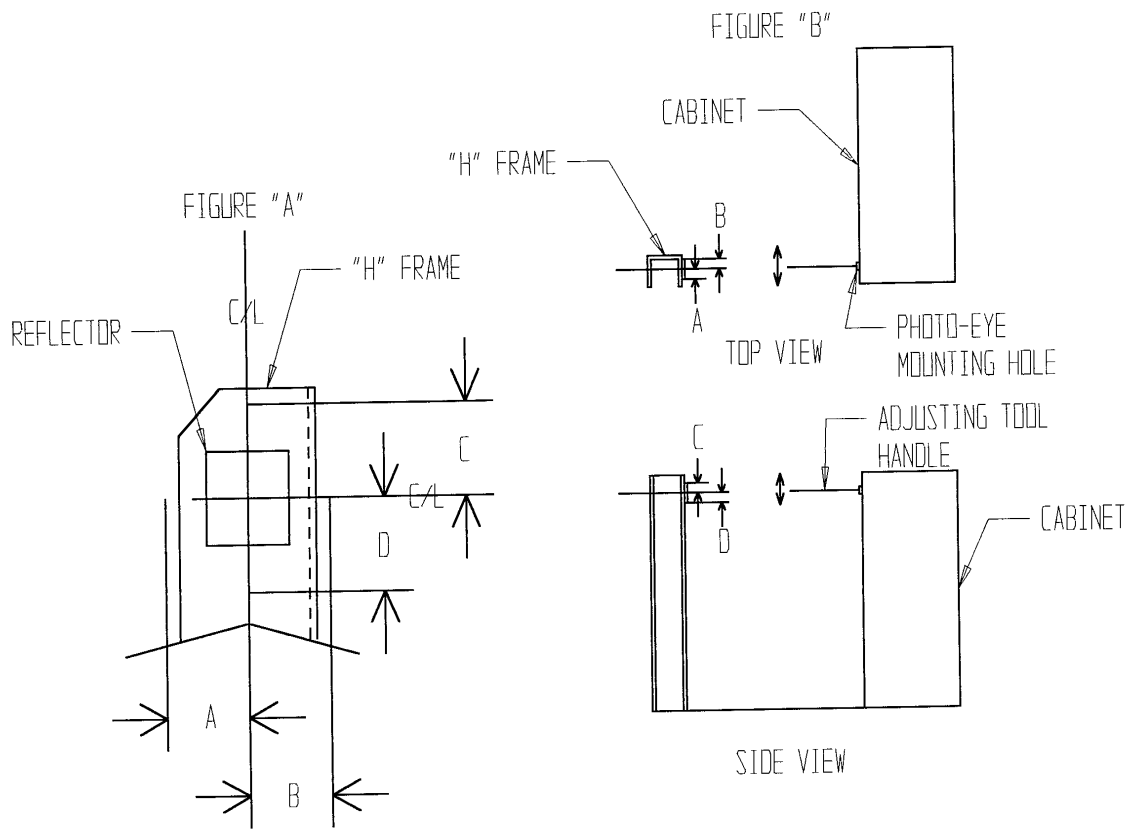

ADJUSTING THE AIM OF A PHOTO-EYE

1. Remove side panel of cabinet.
2. Press the (ENT/RST) button on the timer. This will supply power to the photo-eyes which will be indicated by a red light on at the back of the timer. (If they don't come on, the photo-eye might be out of alignment.)
3. For adjusting the mounting hole on the cabinet, there is an Adjusting Tool available.
 - A. Remove the photo-eye from the cabinet.
 - B. Remove one of the nuts that is threaded onto the Adjusting Tool and insert the threaded end into the hole in the cabinet (from the outside) and thread the nut back on the tool.
 - C. Pull the handle of the Adjusting Tool into the direction of the smaller measurements that you recorded in step #4 (see Figure "B"). You should be able to bend the mounting hole in the cabinet, to align the photo-eye.
4. Install the photo-eye back into the cabinet.
5. Repeat instructions for **CHECKING THE AIM OF THE PHOTO-EYE**. Re-adjust again if necessary.
6. Once this is complete remove the tape from the reflector and put the side panel back on the cabinet.
7. Alignment is now complete.

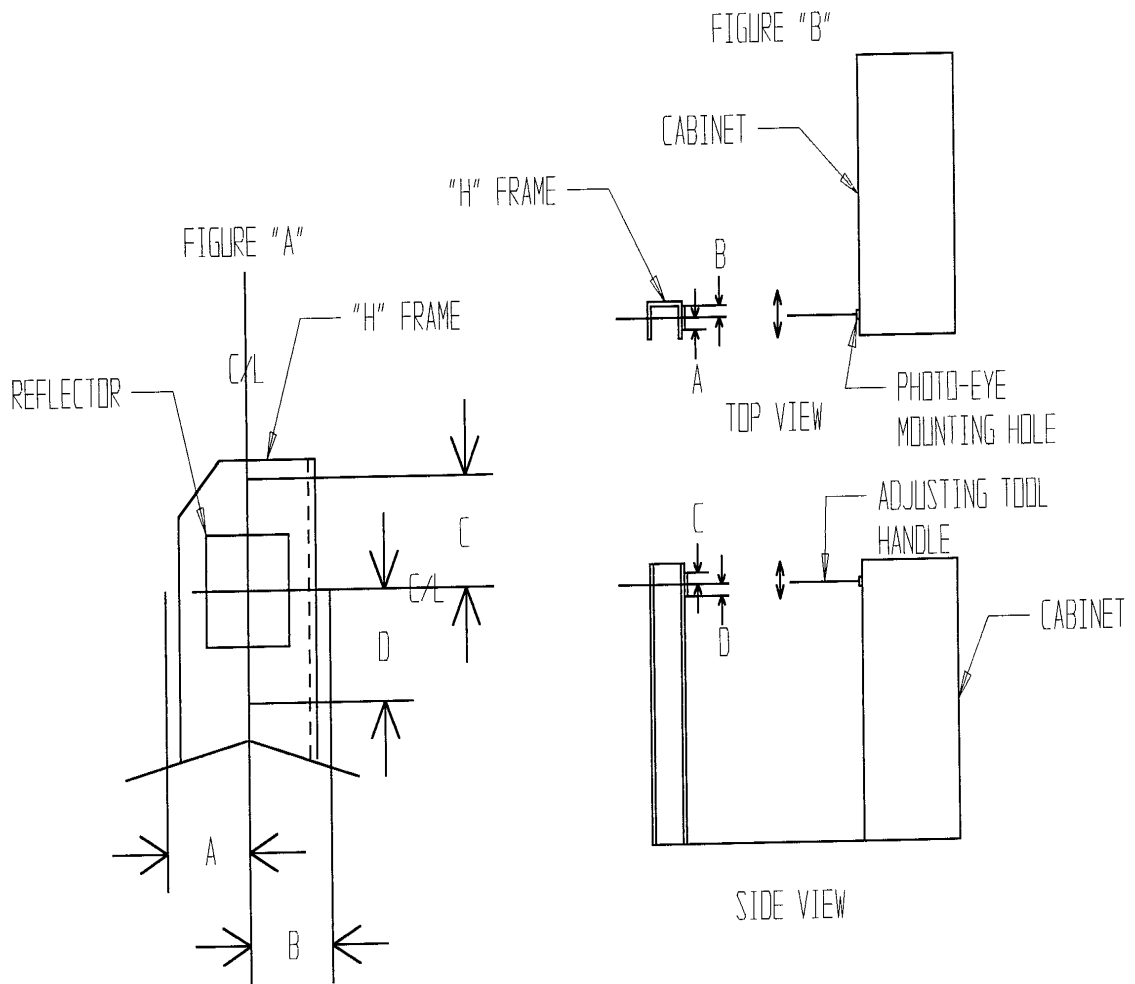

LT60 FRAME PARTS ASSEMBLY

31x76 UNIT

<u>REF. NO.</u>	<u>PART NO.</u>	<u>DESCRIPTION</u>	<u>QTY.</u>
1	LT60FW	MAIN FRAME	1
** 2	1012A	FACE PANEL	1
3	1013	BACK	1
4	1014	SIDE PANEL	1
5	1015	TOP COVER	1
6	1024	DRUM SUPPORT	1
7	1039	MOUNTING BAR	1
** 8	CS4W890	RIGID CASTER	2
** 9	CS4W887	SWIVEL CASTER	2
10	BOS0AB240125	3/8-16x1 1/4" CARR. BOLT SS	4
11	BOS0AU160050	10-24x1/2" PH RHMS SS	12
12	RNA2520A080	RIVNUT	6
13	BOS0AU200125	1/4"-20x1 1/4" PH RHMS SS	6
14	BOS0AU200050	1/4-20x1/2" PH RHMS SS	11
15	PL75-011DX-02	VINYL STRIP	1
16	NUS0EG16	10-24 HEX NUT SS	2
17	BOS0AB280150	1/2-13x1 1/2" CARR BOLT SS	4
18	WASGI050	1/2" STD. LOCK WASHER SS	2
19	NUS0EA28	1/2-13 HEX NUT SS	4
20	SB2210	SNAP BUSHING	1
21	BOS0AU160100	1/4-20x1 PH RHMS SS	3
22	WASGA020	#10 STD. FLAT WASHER SS	2
23	BOS0AA240075	3/8-16x3/4" HHCS SS	16
24	WA98449A011	#10 LOCK WASHER SS	2

** SEE CHANGE LIST

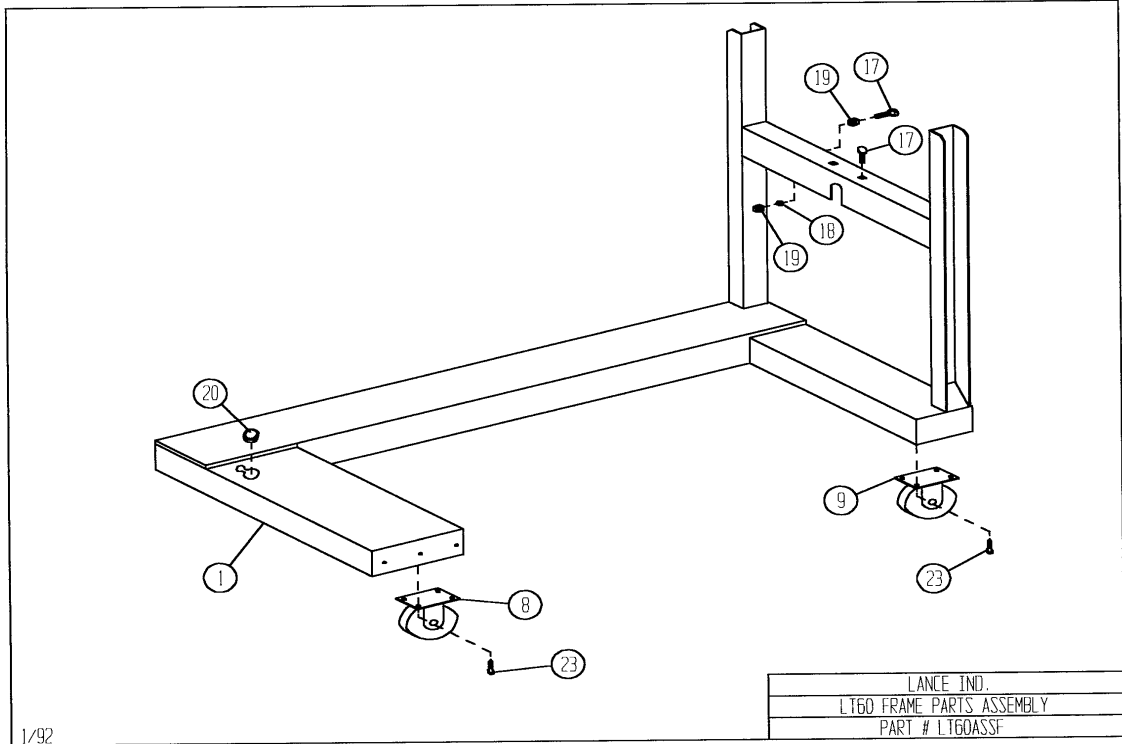

1/92

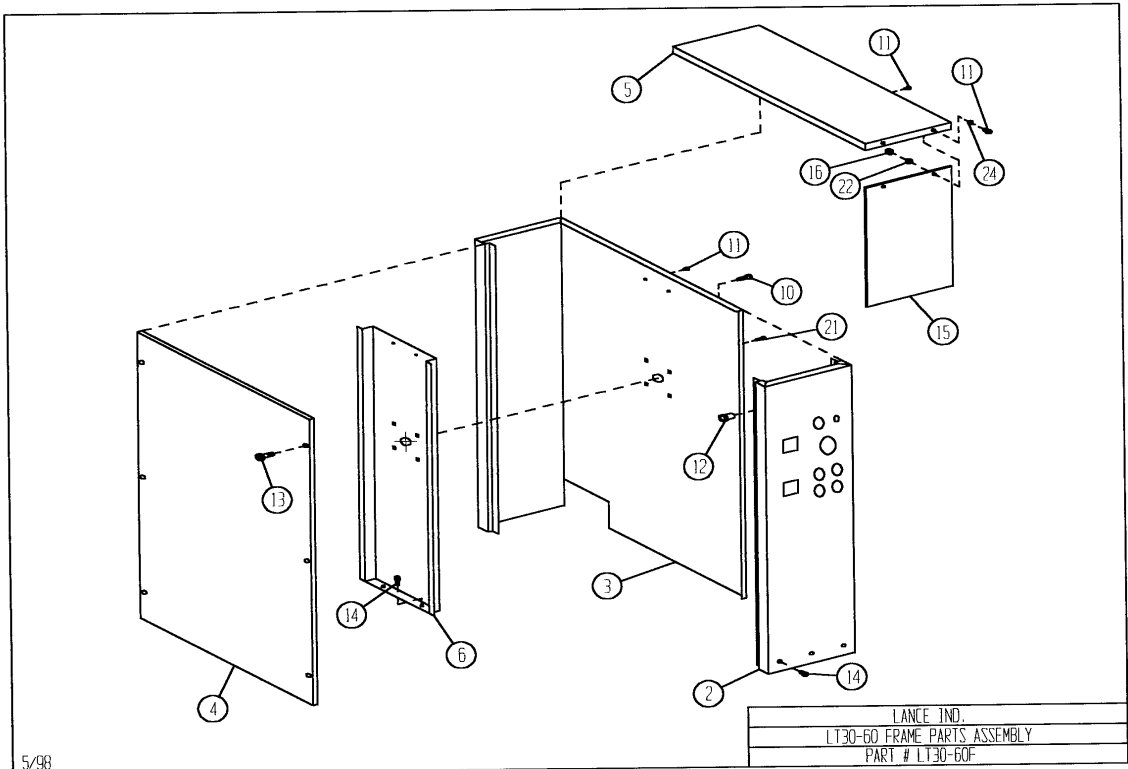

5/98

LT60 VACUUM PARTS ASSEMBLY

31x76 UNIT

<u>REF. NO.</u>	<u>PART NO.</u>	<u>DESCRIPTION</u>	<u>QTY.</u>
1	1036TW	TRAP BRACKET	1
** 2	VU5Z351	VACUUM PUMP	1
** 3	VTAA672K	BALL TRAP	1
4	0002-49	VACUUM PLUG	1
5	BOS0AA200100	1/4-20x1 HHCS SS	4
6	BOS0AU160050	10-24x1/2" PH RHMS SS	3
7	HN5346K35	FEMALE HOSE NIPPLE 3/8"-1/4"	2
8	HN5346K42	FEMALE HOSE NIPPLE 1/4"-1/4"	2
9	HN5346K18	MALE HOSE NIPPLE 3/8"-1/4"	3
10	EL116SC	90 STREET ELBOW 1/4"-1/4"	4
11	TEE101C	TEE 1/4"	1
12	HS26-705AM	3/8" HOSE	3'
13	HS26-702AM	1/4" HOSE	7'
14	PNS025B0150	PIPE NIPPLE	1
15	OR946K26	O-RING	1
* 16	VTAJ554	TRAP BALL	1
* 17	VTAJ473	TRAP FUNNEL	1
** 18	VTAE274	TRAP JAR	1
19	WASGI025	1/4" STD. LOCK WASHER SS	4
20	GATSUGF	VACUUM GAUGE	1

* NOT SHOWN

** SEE CHANGE LIST

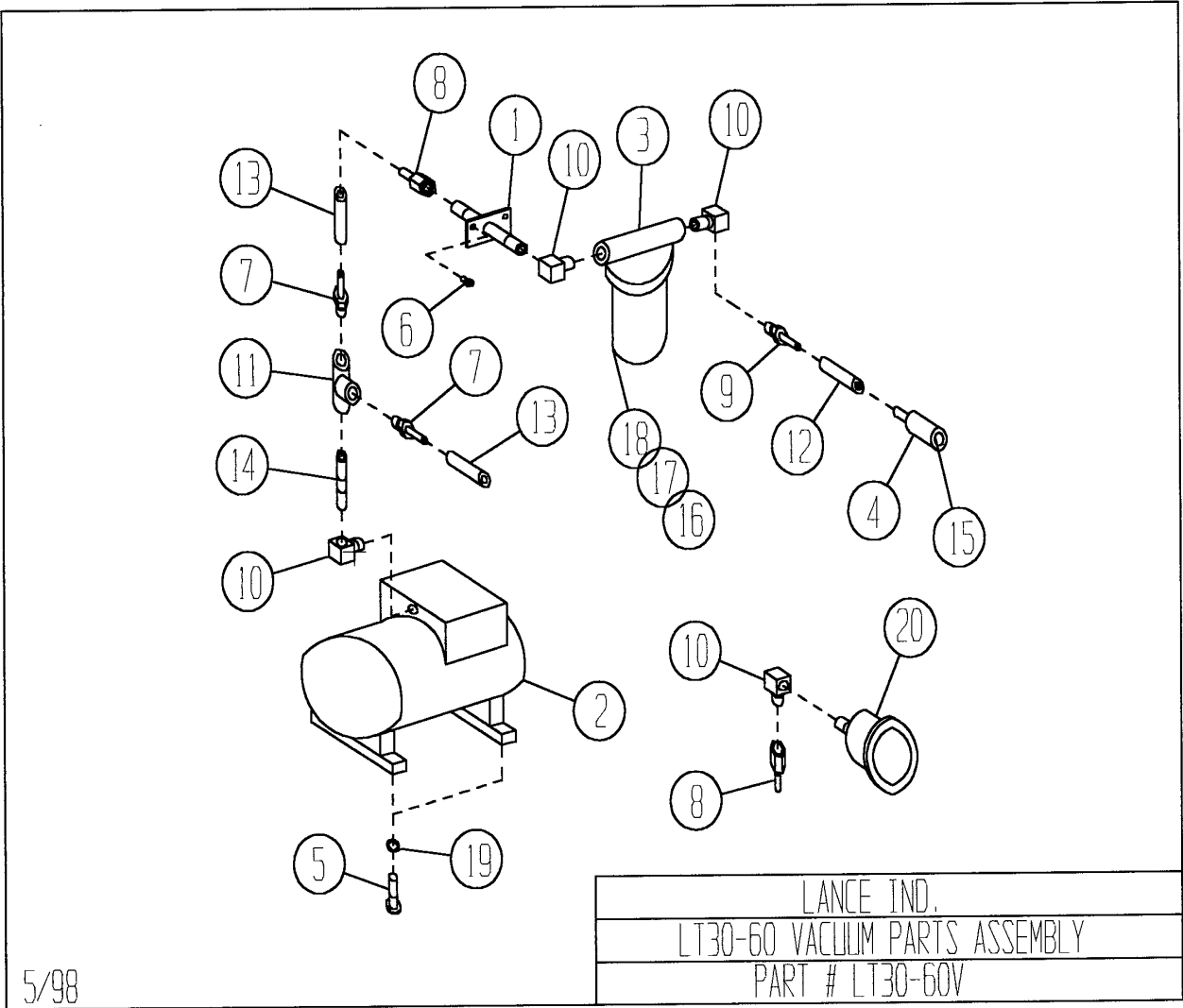

5/98

LT 60 DRIVE-TRAIN ASSEMBLY

31x76 UNIT

<u>REF.</u>	<u>NO.</u>	<u>PART NO.</u>	<u>DESCRIPTION</u>	<u>QTY.</u>
	1	LT60DW	DRUM	1
	2	LT30CW	COVER	1
	3	1030	MOTOR MOUNTING BRACKET	2
**4		MO098032	MOTOR (LESSON)	1
	5	GB175BQ040562	GEAR BOX	1
	6	PBHCFS207-23-1-7/16	FLANGE BEARING	1
	7	SP40B12-7/8	SPROCKET	1
	8	BUSDS-1-7/16	BUSHING	1
	9	SP40SDS60	SPROCKET (FOR 60 CYCLE MACHINES)	1
		SP40SDS48	SPROCKET (FOR 50 CYCLE MACHINES)	1
	10	RC4006000	#40 ROLLER CHAIN	6'
	11	WASGA037	3/8" STD FLAT WASHER SS	4
	12	WASGI037	3/8" STD LOCK WASHER SS	4
	13	NUS0EA24	3/8-16 HEX NUT SS	4
	14	BOS0AB220075	5/16-18 X 3/4" CARRIAGE BOLT SS	4
	15	WASGA031	5/16" STD FLAT WASHER SS	4
	16	WASGI031	5/16" STD LOCK WASHER SS	4
	17	NUS0EA22	5/16-18 HEX NUT SS	4
	18	PBUCP207-23-1-7/16	PILLOW BLOCK BEARING	1
**19		GALT153060	GASKET	1
	20	0002-43	COVER BOLT	4
	21	WASGA050	COVER WASHER	4
	22	PK5993K33	COVER KNOB	4
	23	EL116SC	90 DEG. STREET ELBOW	1
	24	PV4886K56	BRASS VALVE	1
	25	600-56	PIPE NIPPLE	1
	26	BOS0BF700062	10-32 X 5/8" PH TH HD MS SS	4
	27	NUSOEN17	10-32 ACORN NUT SS	4
	28	WASGI025	1/4" STD LOCK WASHER SS	8
	29	WASGA050	1/2" STD FLAT WASHER SS	2
	30	WASGI050	1/2" STD LOCK WASHER SS	2
	31	NUS0EA28	1/2-13 HEX NUT SS	2
**32		PC63745T81	END CAP	1
	33	BOS0AA200100	1/4"-20 X 1 HHCS SS	8
	34	***		
	35	***		
**36		BP900116.02	BRUSH (LESSON)	2
**37		BP900115.01	BRUSH SPRING (LESSON)	2
	38	PW1041	PLASTIC WASHER FOR COVER KNOB	4

** SEE CHANGE LIST

*** NUMBER UNASSIGNED

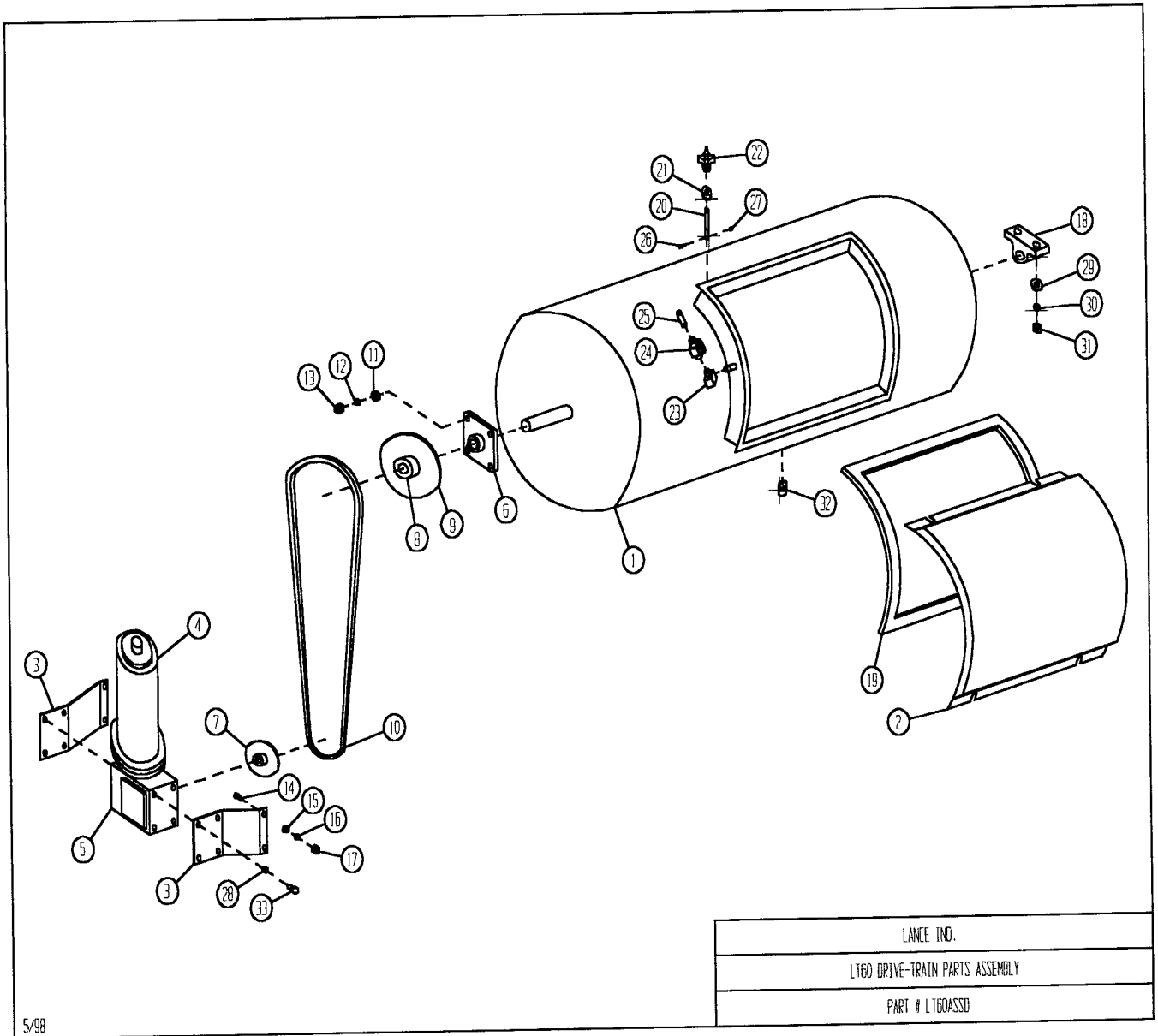

LT 60 ELECTRICAL PARTS ASSEMBLY

31x76 UNIT

<u>REF.</u>	<u>NO.</u>	<u>PART NO.</u>	<u>DESCRIPTION</u>	<u>QTY.</u>
**	1	1016A	ELECTRICAL BOX	1
	2	1018	ELECTRICAL BOX COVER	1
	3	BCBC141	CONTROLLER	1
**	4	BCBR0015	HP RESISTOR	1
**	5	SWP9CSMUON	SELECTOR SWITCH	1
**	6	PBP9CPNRS	PUSH BUTTON-RED	2
**	7	PBP9CPNVG	PUSH BUTTON-GREEN	2
**	8	CBP9B10VN	CONTACT BLOCK-N.O.	3
**	9	CBP9B01VN	CONTACT BLOCK-N.C.	4
	10	CBP9B11VN	CONTACT BLOCK-N.O./N.C.	2
**	11	RL2XC20	RELAY	6
	12	FBP9ACFS5	FLANGE BLOCK	1
**	13	PEATC-7253CR2X3ASX	PHOTOELECTRIC EYE	2
	14	TE2A691	TERMINAL SECTION	15
	15	TE2A696	END SECTION	1
	16	BOS0AU140037	8-32 X 3/8" PH RHMS SS	17
	17	TM88857800	TIMER	1
	18	SO00008258700	SOCKET 8 PIN	1
	19	WA93650A160	WASHER SEAL	1
	20	BPLT30PA-1	BLUE PANEL	1
*	21	SR1200	5/8" STRAIN RELIEF	3
*	22	SR1157	1/2" STRAIN RELIEF	2
	23	GM9600K22	GROMMET	1
*	24	WI1W661	16/3 WIRE	6'
*	25	CR3453	CORD RESTRAINT	1
*	26	CT3500	NYLON CABLE TIES	10
*	27	CL3608	CABLE HOLDER	6
*	28	CT3503	NYLON CABLE TIES	10
*	29	CN4X290	SPLICE CONNECTOR	3
*	30	CN534-0550	1/4"-90 CONNECTOR	4
*	31	CN4X308	RING CONNECTOR	5
	32	BOS0CA120037	6-32 X 3/8" PH PAN HD MS SS	4
	33	NUS0EN12	6-32 ACORN NUT SS	4
	34	NU70205K21	SEALING NUT	1
	35	SK753-2352	SPEED KNOB	1

* NOT SHOW

** SEE CHANGE LIST

<u>REF. NO.</u>	<u>PART NO.</u>	<u>DESCRIPTION</u>	<u>QTY.</u>
*36	CS2W687	POWER CORD 12 FT. LG.	1
37	1012	FACE PANEL	1
**38	00001812300	REFLECTOR	2
39	SPBC-148	5K SPEED POTENTIOMETER	1
40	FHHTB-36I	FUSE HOLDER	2
*41	FU6F019	GGC12- 12 AMP FUSE	2
42	***		
*43	-----	TRANSFORMER (220 & 380 volt units only) (see tag on transformer for part #)	1

- * NOT SHOWN
- ** SEE CHANGE LIST
- *** NUMBER UNASSIGNED

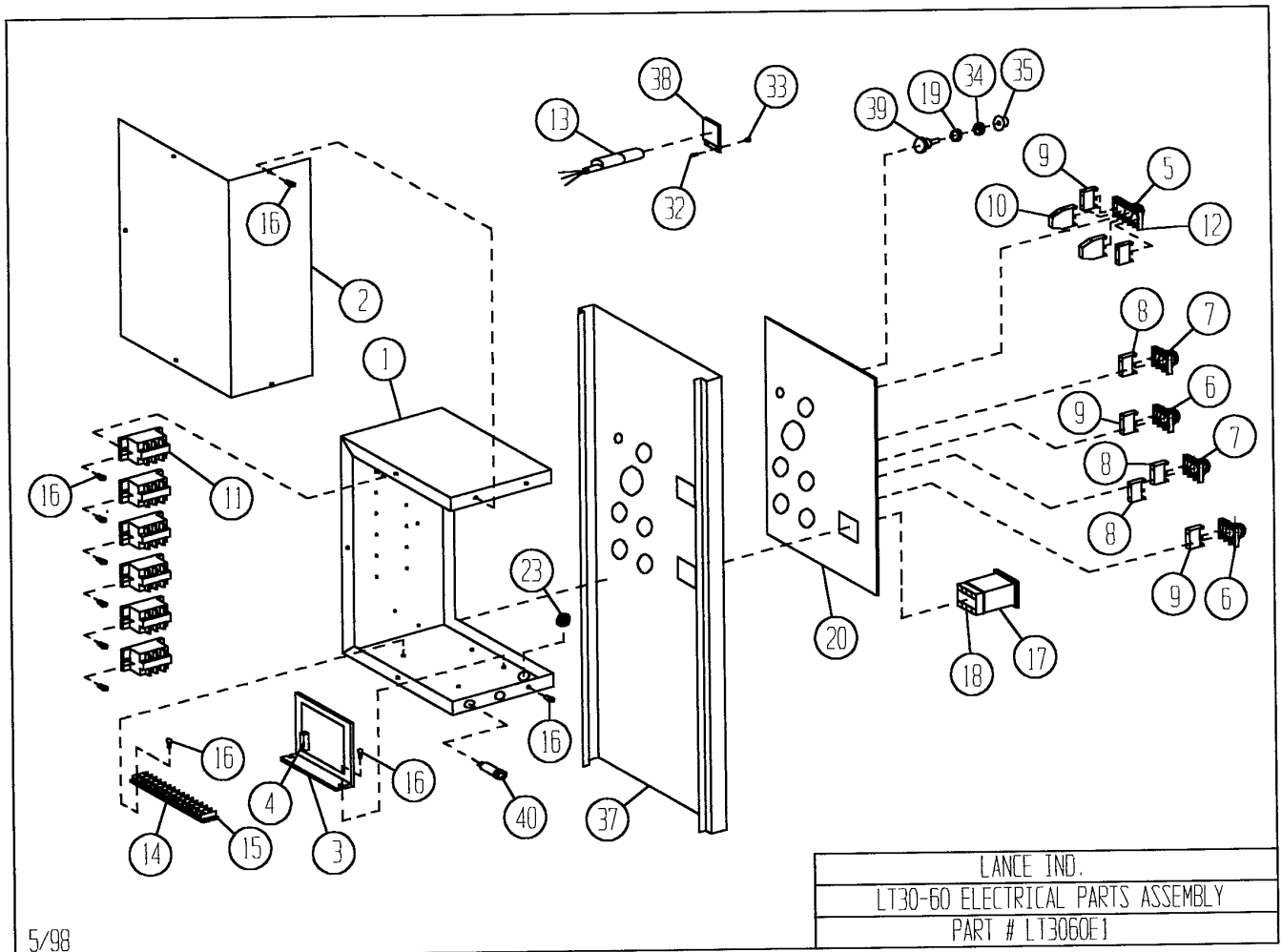

LANCE PARTS CHANGE LIST - LT60

<u>DESCRIPTION</u>	<u>OBSOLETE PART NUMBER</u>	<u>NEW PART NUMBER</u>
RIGID CASTER	CS4X785	CS4W890
SWIVEL CASTER	CS4X783	CS4W887
VACUUM PUMP	VU5Z350	VU5Z351
MOTOR	MOCDP-3330	MO098032
GASKET	GA251A	GALT153060
END CAP	PCN-800D	PC63745T81
BRUSH	BP5011T01	BP900116.02
BRUSH SPRING	BP5012A04	BP900115.01
RELAY	RL2XC37	RL2XC20
SWITCH	SW2A922	SW6P340
POWER CORD	CS6W687	CS2W687
HP RESISTOR	BCBR0025	BCBR0015
BALL TRAP	VTAA672D	VTAA672K
TRAP JAR	VTAA125A	VTAE274
REFLECTOR	00001812400	00001812300
FLANGE BEARING	PBFB220-1-1/4	PBHCFS207-23-1-7/16
PILLOW BLOCK BEARING	PBPB251-1-1/4	PBUCP207-23-1-7/16
BUSHING	BUSDS1-1/4S	BUSDS-1-7/16
PUSH BUTTON	PB2A917	PBP9CPNVG
PUSH BUTTON	PB2A918	PBP9CPNRS
SELECT SWITCH	SW6P340	SWP9CSMUON
CONTACT BLOCK	CB2A932	CBP9B10VN
CONTACT BLOCK	CB2A933	CBP9B01VN
PHOTO-EYE	PEATC-7253AR2X3ASX	PEATC-7253CR2X3ASX
TIMER	TM191-11A6	TM88857800
FACE PANEL	1012	1012A
ELECTRICAL BOX	1016	1016A
RIVNUT 1/4-20	RNA2520A080	RNAHA1420165



THOMAS[®]
 COMPRESSORS
 & VACUUM PUMPS

1419 ILLINOIS AVE., SHEBOYGAN, WI 53082
 (414) 457-4891

First Name in Innovation

MODEL NUMBERS:
807CK60 807CM60 807CP60

Read and understand the following information and instructions included with this product before using. This information is for your safety and to prevent damage to this product.

- ⚠ CAUTION: To reduce risk of electrical shock . . .**
1. Do not disassemble. Disassembly or attempted repairs if accomplished incorrectly can create electrical shock hazard. Refer servicing to qualified service agencies only.
 2. If this plug is supplied with a three pronged plug, connect unit to a properly grounded outlet only.

- ⚠ WARNING: To reduce risk of electrocution . . .**
1. This product should never be left unattended when plugged in.
 2. Always unplug this product immediately after using and store in dry place.
 3. Do not use this product in or near area where it can fall or be pulled into water or other liquids.
 4. Do not reach for this product if it has fallen into liquid. Unplug immediately.
 5. Never operate this product outdoors in the rain or in a wet area.

- ⚠ DANGER: To reduce risk of explosion or fire . . .**
1. Do not use this product in or near explosive atmospheres or where aerosol (spray) products are being used.
 2. Do not pump anything other than atmospheric air.
 3. Do not pump combustible liquids or vapors with this product or use in or near an area where flammable or explosive liquids or vapors may exist.
 4. Do not use this product near flames.

Failure to observe the above safety precautions could result in severe bodily injury, including death in extreme cases.

- ⚠ CAUTION: To prevent injury . . .**
1. Close supervision is necessary when this product is used near children or invalids. Never allow children to operate the unit.
 2. Never operate this product if it has a damaged cord or plug. If it is not working properly. If it has been dropped or damaged. Or if it has fallen into water, return the product to a service center for examination and repair.
 3. Keep the cord away from heated surfaces.
 4. Never block any air openings (inlet) of this product or place it on a soft surface where the openings may be blocked. Keep all air openings free of lint, dirt and other foreign objects.
 5. Never use while sleeping or drowsy.
 6. Never drop or insert fingers or any other object into any openings.
 7. Do not operate this product where oxygen is being administered.
 8. This unit may be thermally protected and can automatically restart when the protector resets. Always disconnect power source before servicing.
 9. Wear safety glasses or goggles when operating this product.
 10. Use only in well ventilated areas.
 11. Do not use any tools or attachments without first determining maximum air pressure for that tool or attachment.
 12. Never point any air nozzle or air sprayer toward another person or any part of the body.
 13. All electrical products generate heat. To avoid serious burns never touch unit during or immediately after operation.

⚠ CAUTION: Federal law restricts this device to sale by or on the order of a physician.

SAVE THESE INSTRUCTIONS

⚠ Warning: Thomas compressors are precision-made, and carefully assembled and wired. Therefore do not disassemble or attempt to repair these products. Only qualified personnel should perform repair service. ⚠

IMPORTANT NOTICE TO PURCHASER: WARRANTY AND EXCLUSIVE REMEDIES

Thomas finished OEM products, when properly installed and under normal conditions of use, are warranted by Thomas to be free from defects in material and workmanship at time of shipment. Warranty claims regarding OEM limited products must be asserted within 13 months (the "warranty period") from date of manufacture encoded on the product (unless otherwise agreed in writing or specified in a Thomas OEM Quotation). The customer's exclusive remedy against Thomas for a warranty claim or otherwise, shall be limited to repair or replacement of the subject OEM finished product if it is shown to have been defective in material and workmanship at time of shipment, and then only if the claim is asserted during the warranty period. Thomas maximum liability under this exclusive remedy shall never exceed the cost of the subject product and Thomas reserves the right, at its sole discretion, to refund the purchase price in lieu of repair or replacement. Except for such warranty and exclusive remedy as stated (and except for the express warranty of title) THOMAS DISCLAIMS ALL OTHER WARRANTIES WITH RESPECT TO ITS OEM FINISHED PRODUCTS, WHETHER IMPLIED, AND SPECIFICALLY DISCLAIMS THE IMPLIED WARRANTIES OF MERCHANTABILITY AND FITNESS FOR A PARTICULAR

PURPOSE. IN NO EVENT SHALL THOMAS BE LIABLE TO CUSTOMER OR THIRD PARTIES IN WARRANTY, CONTRACT, NEGLIGENCE, STRICT LIABILITY, OR OTHERWISE, FOR ANY DAMAGES, WHETHER INCIDENTAL OR CONSEQUENTIAL, WHICH ARE ALLEGED TO HAVE BEEN CAUSED BY ONE OR MORE OF OUR PRODUCTS BEYOND THE COST TO THE CUSTOMER OF THE SUBJECT PRODUCT OR PRODUCTS. THE EXCLUSIVE REMEDY FOR ANY CLAIM HAVING BEEN LIMITED TO REPAIR OR REPLACEMENT AS AFORESAID.

Because Thomas OEM warranties and remedies extend only to our direct customers, the customer is not authorized to extend warranties on our behalf to anyone. Unauthorized extensions of warranties by the customer shall remain customer's responsibility.

CUSTOMER IS RESPONSIBLE FOR DETERMINING THE SUITABILITY OF OUR PRODUCTS FOR CUSTOMER'S USE OR RESALE, OR FOR INCORPORATING THEM INTO OBJECTS OR FOR APPLICATIONS WHICH CUSTOMER DESIGNS, ASSEMBLES, CONSTRUCTS OR MANUFACTURES.

PARTS LIST AND DRAWING

No.	Part No.	Description	Qty.
1	663190	Shaft, Rotor & Bearing Assembly	1
2	607583	Connecting Rod Assembly	1
3	667177	Eccentric & Bearing Assembly	1
4	656283	Valve Plate Assembly	1
5	605047	Flag Terminal - Stator	3
6	605018	Terminal Screw - Ground	1
7	614490	Front Cover Assembly	1
8	602228	Relay Switch	1
9	608414	Stator 115 - 60 Hz	1
10	604128	Lead Wire - Relay to Line	1
11	617425	Motor End Cap	1
13	615619	Piston Sleeve	1
14	615600	Tubing - Stator Leads	1
15	623638	"O" Ring Sleeve	1

No.	Part No.	Description	Qty.
16	625436	Screw - Head	6
17	625245	Screw - Relay Switch	2
18	625114	Cap Screw - Connecting Rod	1
19	625354	Screw - Fan	1
20	625448	Screw - Front Cover	4
21	626014	Washer - M.E.C.	4
22	625107	Screw - Stator	4
23	626309	Washer - Fan	1
24	626328	Terminal Nut - Ground	1
25	626509	Lockwasher - Stator Screw & Fan	5
26	626323	Terminal Washer - Ground	2
27	633222	Strain Relief	1
28	633228	Cord	1

No.	Part No.	Description	Qty.
29	638358	"O" Ring Gasket - Head	1
30	633718	Fan	1
31	646101	Ball Bearing	2
33	606281	Head	1
34	651430-504	Housing	1
35	614951	Bearing Cover	1
36	625231	Screw - M.E.C.	4
37	605387	Filter Assembly	1
38	607034	Insulated Connector	2
39	631519	Locite #290	AR
40	636168	TYRap Tie (Not Shown)	2
41	631510	Locite #242	AR
42	638127	Plug (Snap-In) (Not Shown)	1

MODEL 607CK60		
Delete	Description	Add
602228	Relay Switch	602251
608413	Stator	608333
663190	Shaft, Rotor, Bearing Assembly	663996

Model 607CK60			
Key	Add	Delete	
1	667199	Shaft, Rotor & Brg. Ass'y.	663190
7	614770	Front Cover Ass'y.	614490
9	608668	Stator	608414
33	661218	Head	660828
36	625357	Screw - Stator	625107

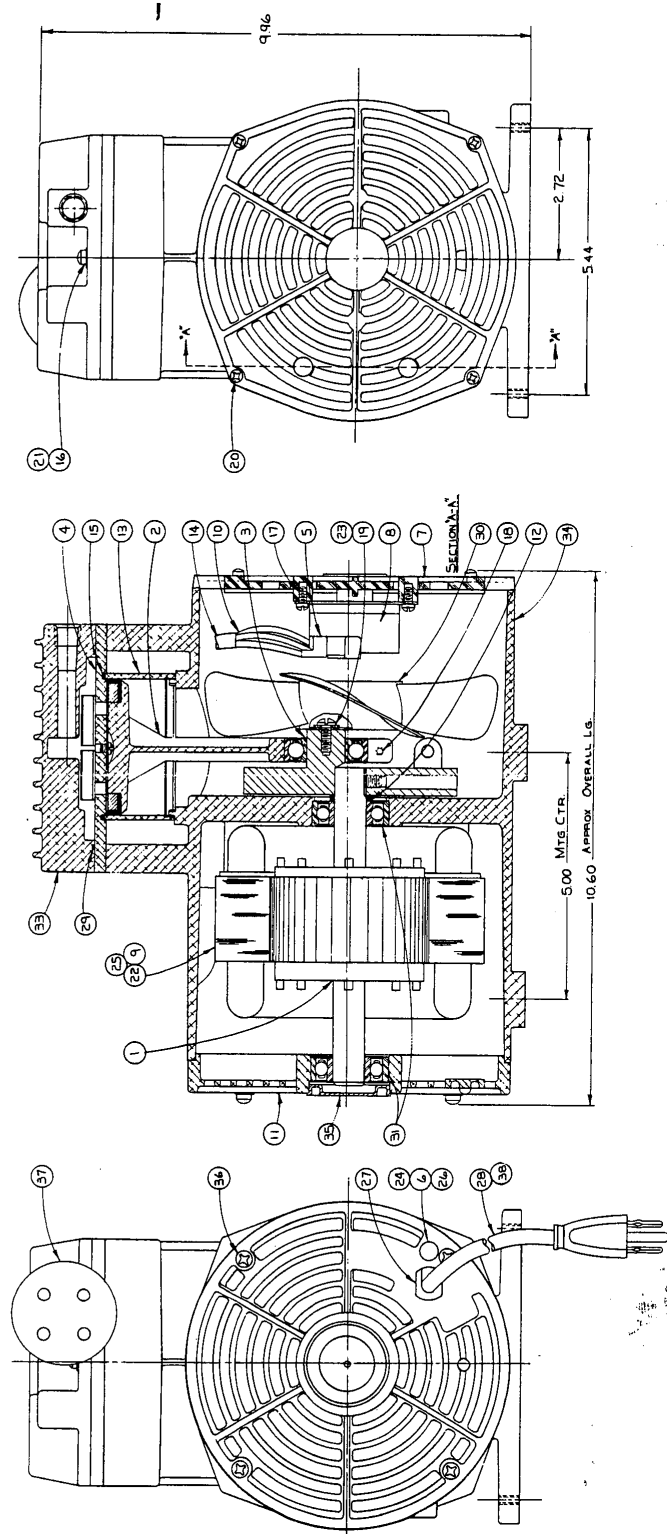

GROVE GEAR FLEX-A-LINE SPEED REDUCERS

Installation, Lubrication and Maintenance Instructions

WARNING

Read ALL instructions prior to operating reducer. Injury to personnel or reducer failure may be caused by improper installation or operation. This reducer is not a fail-safe device or a self-locking device. **Rotating equipment is potentially dangerous and should be guarded at all times.**

INSTALLATION

1. General

Your Grove Gear Flex-A-Line Speed Reducer should be accurately aligned and bolted securely to a flat, level surface. Check output shafts to ensure proper tension and alignment of loads. Refer to factory any non-standard mounting positions. On Unit sizes 1262 and larger all applications with vertical input or output shafts should be referred to the factory. Special provisions for bearing lubrication may be required.

CAUTION

For safety, purchaser or user should provide protective guards over all shaft extension and any moving apparatus mounted thereon. The user is responsible for checking all applicable safety codes in his area and providing suitable guards.

To minimize deflection and bearing load, mount connections as close to reducer as possible. Check to make certain application does not exceed published overhung load capacities in the current Grove Gear Industrial Gear Drives Catalog, available free upon request.

CAUTION

The system of connected rotating parts must be free from critical speed, torsional or other type vibration, no matter how induced. The responsibility for this system analysis lies with the purchaser of the speed reducer.

2. Initial Operation

- A. Make certain the highest pipe plug (installed for shipping only) is removed and the vent plug is installed prior to operating.
- B. Check oil level before operating. Oil should be filled to bottom edge of oil level plug using the lubricant specified in this bulletin.

CAUTION

Do not overfill with oil, or failure could result in damage to property or personal injury.

- C. Test run unit to verify operation. All Flex-A-Line units are fully reversible, and can be operated in either direction of rotation. **This reducer is not a fail-safe device or a self-locking device and all shaft extensions should be guarded at all times.**

STANDARD SPEED REDUCER MOUNTING POSITIONS AND VENT PLUG LOCATIONS

Before putting unit into operation, substitute the vent plug for the solid pipe plug at the position desired. Arrows indicate the recommended vent plug locations.

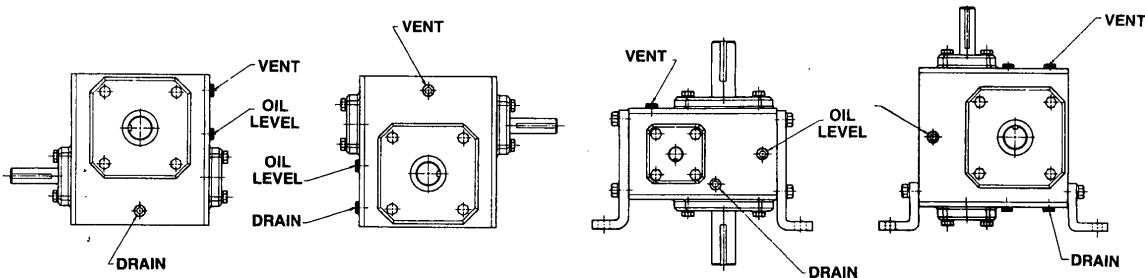

On Unit sizes 1262 and larger all applications with vertical input or output shafts should be referred to the factory. Special provisions for bearing lubrication may be required.

GROVE GEAR

Division of Regal-Beloit Corporation
1524 15th Avenue • Union Grove, WI 53182
414/878-3755 • FAX: 414/878-1968

LUBRICATION

With the exception of Unit sizes 1700, 1800 and 11000 which are shipped DRY, all reducers ordered from the factory will be filled to the proper level with lubricant. After the installation of the breather plug, the unit is ready for use. Before installing the breather plug, determine the proper position according to reducer mounting positions and vent plug locations. (See drawings at bottom on front of this page)

CAUTION

In the Food and Drug Industry (including animal food), consult the petroleum supplier for recommendation of lubricants which are acceptable to the Food and Drug Administration and/or other authoritative bodies having jurisdiction. Factory supplied oil is not suitable for these applications or this industry.

Oil should be changed every 6 months or 2,500 operating hours (whichever comes first) under Class 1 service. Refer to Grove Gear Catalog for class of service guidelines.

CAUTION

Oil should be changed more often if reducer is used in a higher class of service, i.e., II or III or in a severe environment, i.e., dusty, humid.

The precision-made gears and bearings in Flex-A-Line Speed Reducers require high-grade lubricants to maintain trouble-free performance. For best results use lubricants on the following chart or refer to current Grove Gear Catalog.

MANUFACTURER'S RECOMMENDED LUBRICANTS

Manufacturer	15° to 60° F Ambient Temperature AGMA Compounded No. 7	50° to 125°F Ambient Temperature AGMA Compounded No. 8
Amoco Oil Co.	Worm Gear Oil	Cylinder Oil #680
Chevron USA, Inc.	Cylinder Oil #460X	Cylinder Oil #680X
Exxon Co. USA	Cylesstic TK-460	Cylesstic TK-680
Gulf Oil Co.	Senate 460	Senate 680D
Mobile Oil Corp.	600W Super	Extra Hecla Super
Shell Oil Co.	Valvata Oil J460	Valvata Oil J680
Sun Oil Co.	Gear Oil 7C	Gear Oil 8C
Texaco	Honor Cylinder Oil	650T Cylinder Oil
Union Oil Co. of California	Steaval A	Worm Gear Lube 140

WORM GEAR REDUCERS OIL CAPACITIES (ozs.)

MOUNTING POSITION	UNIT SIZE														
	1100	1133	1154	1175	1206	1238	1262	1300	1325	1425	1525	1600	*1700	*1800	*11000
WORM OVER	3	5	10	15	21	25	45	55	73	135	200	310	563	768	1152
WORM UNDER	4	7	14	18	25	30	49	61	89	127	216	330	525	822	1280
VERTICAL OUTPUT	4	6	13	16	23	26	46	58	74	120	216	320	332	460	640
"J" MOUNT	3	7	12	16	24	25	47	60	75	126	216	325	585	800	1200

*Shipped without lubricant.

MAINTENANCE

Your Grove Gear reducer has been tested and adjusted at the factory. Dismantling or replacement of components must be done by Grove Gear to maintain the warranty.

Frequently check the oil level of the reducer. If oil level is low (refer to reducer mounting position chart) add lubrication through filler plug until it comes out the oil level plug.

Inspect vent plug often to insure it is clean and operating.

CAUTION

If unit has been special ordered with synthetic oil, do not mix compounded oil and synthetic oil in reducer.

CLASS OF SERVICE

All capacity ratings are based on American Gear Manufacturers Association (AGMA) Standards. Load conditions must be within cataloged ratings published in the current Grove Gear Catalog (available upon request).

WARRANTY

See catalog for warranty terms and conditions.

GROVE GEAR

Division of Regal-Beloit Corporation
1524 15th Avenue • Union Grove, WI 53182
414/878-3755 • FAX: 414/878-1968

QUILL MOTOR FLANGE UNIT

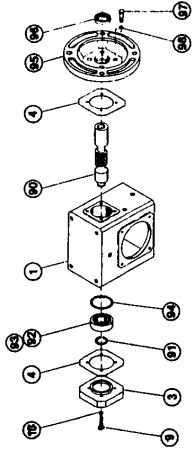

FAN UNIT
For Models 1325, 1425 and 1525 Only.

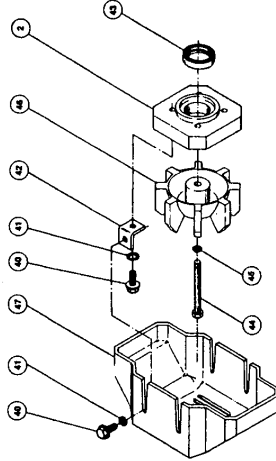

LONG MOTOR FLANGE AND COUPLING KIT

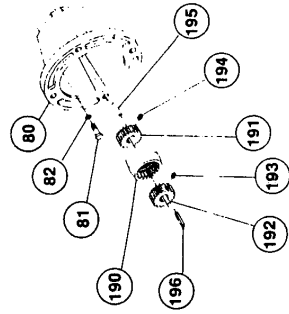

SINGLE REDUCTION UNIT

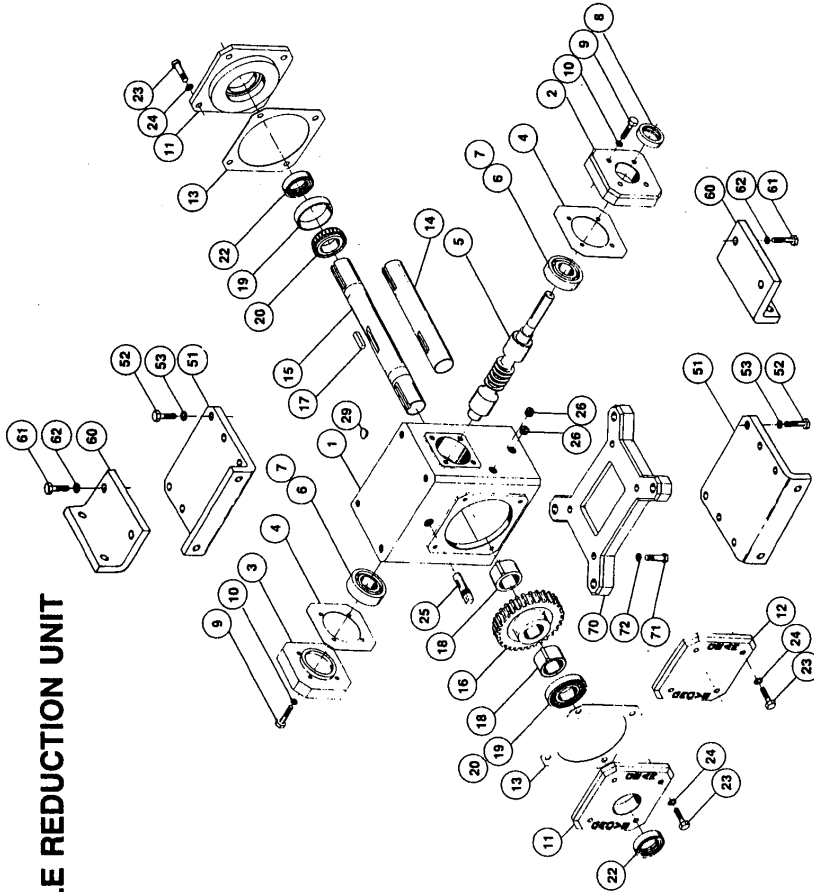

HOLLOW OUTPUT SHAFT UNIT

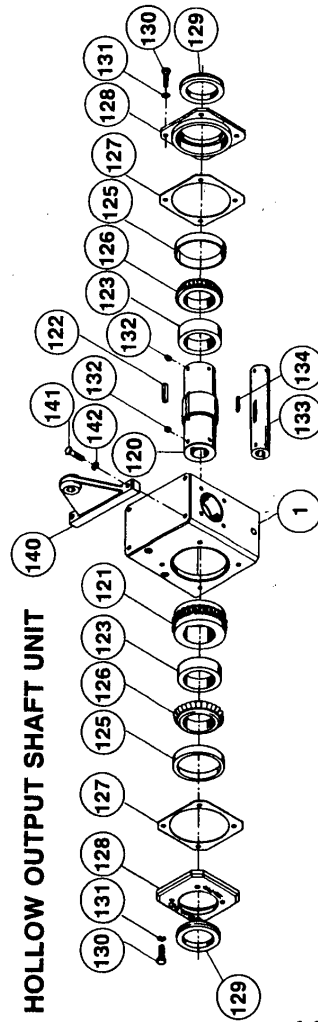

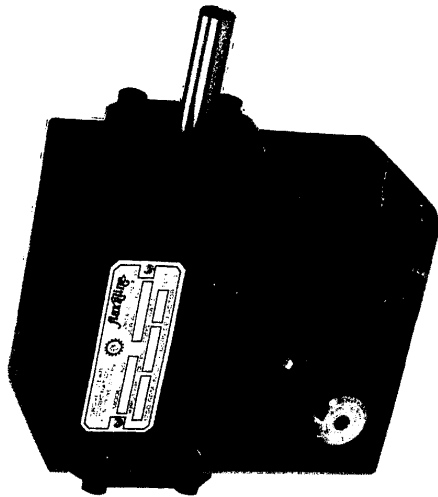

Flexaline® Right Angle Worm Gear Speed Reducers

“Versatility
in Industrial Power Transmission
Applications”

FLEXALINE® GEAR DRIVES
PARTS LIST—SINGLE REDUCTION

Item No.	Description	Qty.	Item No.	Description	Qty.
1	Gear Housing	(1)	80	Long Motor Flange Unit	(1)
2	Input Cover (Seal)	(1)	81	C Face Motor Flange	(4)
3	Input Cover (Bearing)	(1)	82	Hex Head Capscrew	(4)
4	Input Cover Gaskets	(as req'd)		Lock Washer	
5	Input Shaft	(1)			
6	Input Bearing (Cup)	(2)	90	Quill Motor Flange Unit	(1)
7	Input Bearing (Cone)	(2)	91	Quill Input Shaft	(1)
8	Input Oil Seal	(1)	92	Retaining Ring (Shaft)	(1)
9	Hex Head Capscrew	(8)	93	Input Bearing (Cup)	(2)
10	Lock Washer	(8)	94	Input Bearing (Cone)	(2)
11	Output Cover (Seal)	(1)	95	Retaining Ring (Housing)	(1)
12	Output Cover (Bearing)	(1)	96	Quill Motor Flange	(1)
13	Output Cover Gaskets	(as req'd)	97	Oil Seal	(1)
14	Single Output Shaft	(1)	98	Hex Head Capscrew	(4)
15	Double Output Shaft	(1)		Lock Washer	(4)
16	Worm Gear	(1)			
17	Gear Key	(1)	110	Output Flange Unit	(1)
18	Gear Spacer	(2)	111	Output Flange (Hollow)	(1)
19	Output Bearing (Cup)	(2)	112	Output Flange (Solid)	(1)
20	Output Bearing (Cone)	(2)	113	Output Cover (Ground Face)	(1)
22	Output Oil Seal	(1)	114	Hex Head Capscrew	(4)
23	Hex Head Capscrew	(8)*		Lock Washer	(4)
24	Lock Washer	(8)*			
25	Vent Plug	(1)	120	Hollow Output Shaft Unit	(1)
26	Pipe Plug	(2)	121	Hollow Output Shaft	(1)
29	Protective Plug	(4)	122	Worm Gear (Hollow)	(1)
			123	Worm Gear Key	(1)
40	Fan Unit	(4)	125	Worm Gear Spacer	(2)
41	Slotted Hex Head Capscrew	(4)	126	Output Shaft Bearing (Cup)	(2)
42	Plain Flat Washer	(4)	127	Output Shaft Bearing (Cone)	(2)
43	Fan Bracket	(4)	128	Output Gaskets	(as req'd)
44	Oil Seal	(1)	129	Output Cover	(2)
45	Hex Head Capscrew	(1)	130	Output Oil Seal	(2)
46	Lock Washer	(1)	131	Hex Head Capscrew	(8)
47	Fan	(1)	132	Hex Head Capscrew	(8)
			133	Lock Washer	(8)
			134	Set Screw	(6)
51	Vertical Risers Unit	(2)	136	Shaft Bushing	(1)
52	High and Low Riser Bracket	(2)	137	Bushing Kit	(1)
53	Hex Head Capscrew	(8)	140	Torque Bracket	(1)
			141	Hex Head Capscrew	(1)
			142	Lock Washer	(8)
60	"J" Mount Unit	(2)	190	Coupling Kits	(1)
61	"J" Mount Bracket	(4)	191	Coupling Sleeve	(1)
62	Hex Head Capscrew	(4)	192	Coupling Gear	(1)
			193	Coupling Gear	(1)
70	Horizontal Base Unit	(1)	194	Set Screw	(1)
71	Horizontal Base	(4)	195	Key	(1)
72	Hex Head Capscrew	(4)	196	Key	(1)

*1425 Unit has (10) and 1325 Unit has (16)

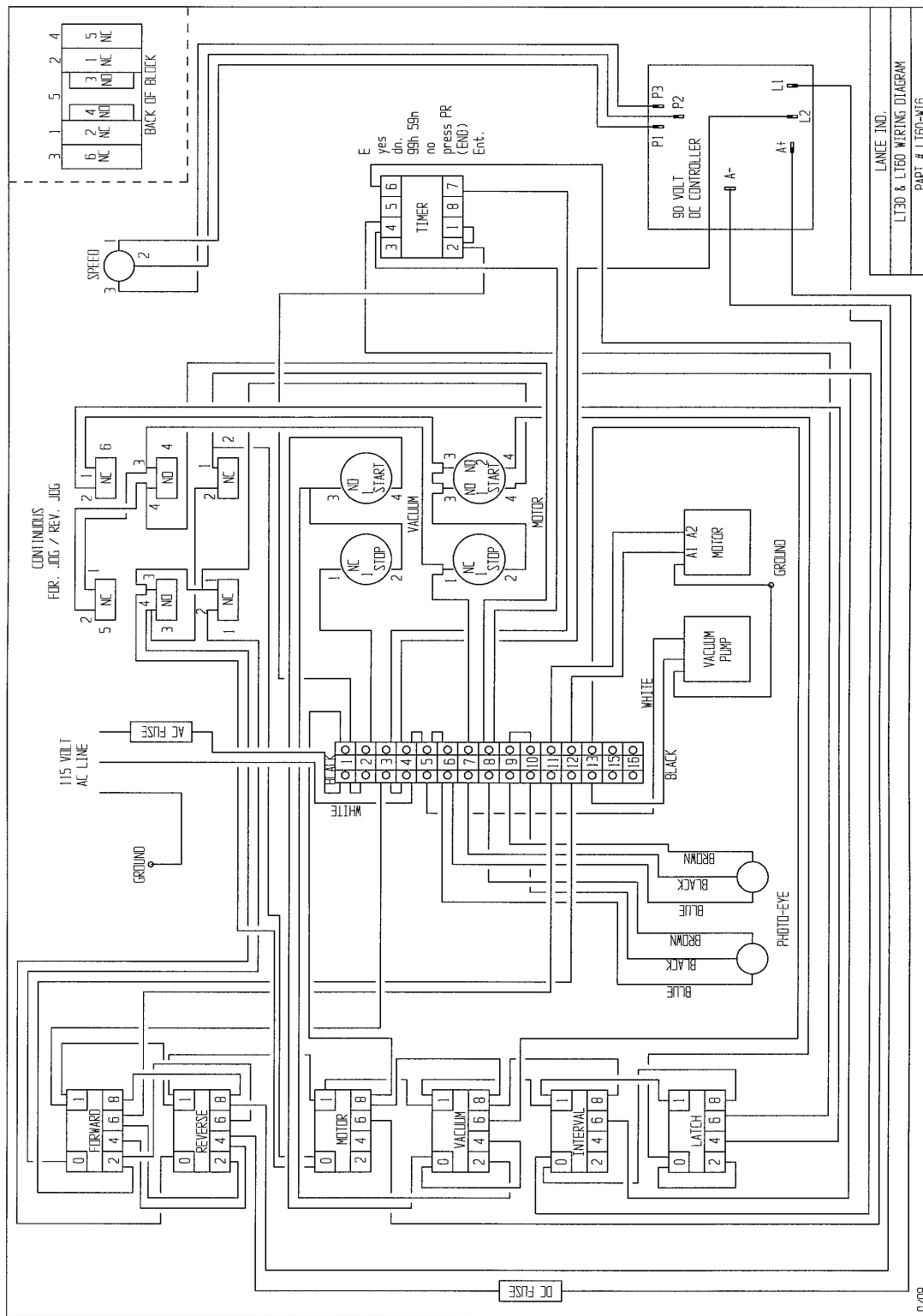

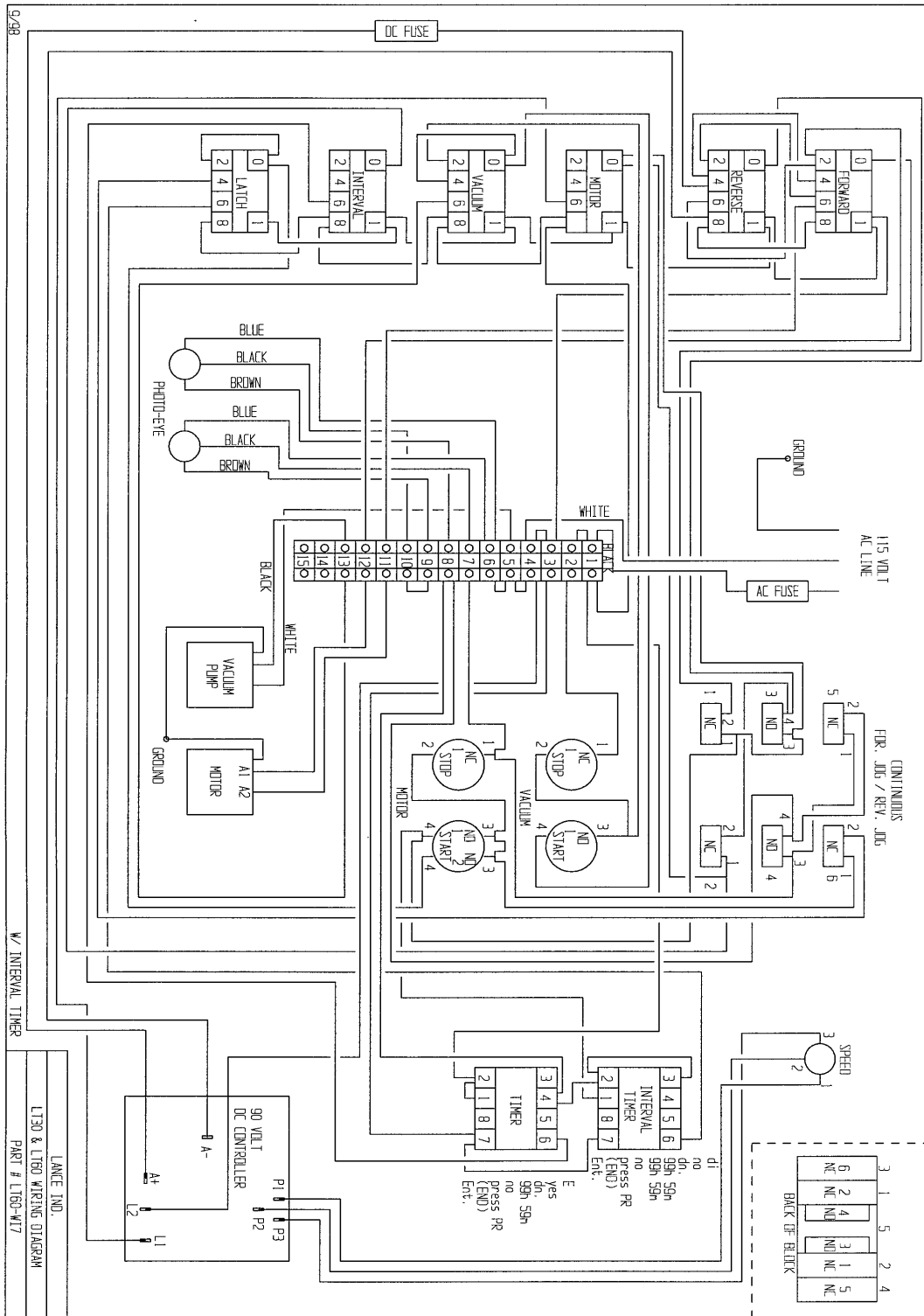

9/98

W/ INTERVAL TIMER

LANCE IND.
L130 & L160 WIRING DIAGRAM
PART # L160-W17