



OWNER'S MANUAL

FOR

LANCE MASSAGE TUMBLER

LT-5

TABLE OF CONTENTS

<u>SECTIONS:</u>	<u>PAGE NO.</u>
SPECIFICATION SHEET	2
INSTALLATION INSTRUCTIONS	3
OPERATING INSTRUCTIONS	4,5
CLEANING INSTRUCTIONS	6
MAINTENANCE	7
TROUBLESHOOTING GUIDE	8
PARTS LIST	
- VACUUM	9
- FRAME	10
- DRIVE TRAIN	11
- ELECTRICAL	12
- STAINLESS DRUM	13
VACUUM PUMP	14-15
GEARMOTOR	16-22
WIRING DIAGRAM	23
TIMER MANUAL	
DC CONTROLLER MANUAL	

MACHINE MODEL NO. _____

SERIAL NO. _____

LT 5 SPECIFICATION SHEET

CONSTRUCTION

All Stainless Steel Construction with USDA approval.

PHYSICAL DIMENSIONS

Length	32"
Width	20"
Height	21"

PRODUCT CAPACITY

STAINLESS DRUM

Gallons	10
Liters	38
Pounds	50

VACUUM PUMP SYSTEM

Maximum Vacuum Liquid Trap	26"
-------------------------------	-----

DRUM SPEED

Variable Speed	1-20 RPM
----------------	----------

TIMER CONTROLS

Tumble Timer	99m 59s
--------------	---------

ELECTRICAL

115 Volts, 60 cycle Variable Speed Motor	.83 Amps
Vacuum Pump	3.3 Amps

Specifications subject to change at anytime.

INSTALLATION INSTRUCTIONS

A. Unpacking

1. Carefully remove machine and drum from the boxes.
2. Inside the drum is a box with the paddles for the drum and the vacuum jar assembly.
3. Remove the plug from the top of the tumbler.
4. Remove the cap from the pipe on the jar assembly. Screw the pipe into the hole from where the plug was removed on the tumbler and tighten securely. (There is pipe tape on the threads to seal them.)
5. Wipe down outside of the machine and drum.
6. Clean inside of the drum.

B. Checking Control Panel

1. Plug the power cord into 115 Volt Receptacle with a 15 amp. Circuit breaker.

C. Check Vacuum Pump Control

1. Turn on the vacuum pump. It should run.

D. Check Tumbler Motor Control

1. Set variable speed control to 20.
2. Set tumbler timer to 2 minutes. (See "SETTING THE CONTROL TIMER" in the Operation Instructions section.)
3. Leave the drum off the tumbler wheels.
4. Turn on the tumbler switch - the wheels will now turn.
5. Turn the variable speed control up and down. The wheels will speed up and slow down.
6. The wheels will turn until the tumbler timer counts down to zero at which time the wheels will stop.
7. Turn off the tumbler switch.
8. Press the (RST/ENT) button on the tumbler timer.
9. The machine is now ready to use.

OPERATING INSTRUCTIONS

A. Loading and Tumbling

1. Clean the machine drum.
 2. Put the gasket on the cover.
 3. Load the product into the drum.
 4. Place the cover on the drum.
 5. Plug the machine into a 115 volt receptacle.
 6. Turn on vacuum pump.
 7. Open vacuum valve on the drum (on the drum cover).
Make sure the vacuum passage to the drum is clean).
 8. Push vacuum hose onto drum fitting.
 9. Run vacuum pump until 15 inches of vacuum is drawn. (Higher vacuum can be drawn if you want to.)
 10. Shut off the valve on the drum.
 11. Remove the hose.
 12. Turn off the vacuum pump.
 13. Set the drum on machine wheels (with cover toward control panel).
 14. Set the tumbler timer to the desired time.
 15. Set the variable speed knob to the desired speed.
 16. Make sure the vacuum hose is disconnected.
 17. Turn on the motor switch. The drum will now rotate until the tumbler timer runs down to zero.
 18. To restart the tumbling process after the time has timed down to zero. Turn the motor switch off.
 19. Press the (RST/ENT) button on the timer, the timer will reset to its preset time.
 20. Turn the motor switch on to start the time cycle again.
- * It can be stopped at any time by turning off the motor switch.
- * To restart the machine, turn on the motor start switch. It will run for the time remaining on the timer.

B. Unloading the Drum

Manual Unloading

1. Remove the drum from the machine and set on a flat surface.
2. Open the vacuum valve on the cover to release the vacuum.
3. Remove the cover.
4. Unload the drum.

SETTING THE CONTROL TIMER

Direct start continuous tumbling

1. Press (RST/ENT) button on the tumbler timer.
 2. Set the set-point on the tumbler timer for total tumbling time (time required for the drum to rotate.)
 3. To set the time on the tumbler timer press the (PR) button.
 4. Notice the number that is flashing, press the button with the arrow pointing to right to the desired position you want to change (the timer is set for hour-min.).
 5. Press the button with the arrow pointing up to set the desired time (each position has to be done separately).
 6. After the time is set press the (RST/ENT) button to enter the time.
 7. Press the (RST/ENT) again to change the current time on the timer.
 8. The tumbler timer is ready to run.
 9. Turn on the tumbler switch to begin the cycle.
- * The tumbler can be stopped by turning the motor switch off. The tumbler timer will maintain it's time.
- * To restart the tumbler turn the motor switch on. The tumbler timer will continue from where it left off. Pressing the reset button on the tumbler timer in the middle of a tumbling cycle will reset the timer to the preset time setting.

CLEANING INSTRUCTIONS

CLEANING YOUR MACHINE

Remove lid and rinse. The drum can be cleaned with your standard cleaning solution in a sink.

FLUSHING VACUUM VALVE ON COVER

Open valve and thoroughly flush with water. This must be done between loads, before pulling vacuum on the drum. If the valve is not cleaned properly, food particles will be drawn into the vacuum hose.

CLEANING VACUUM HOSE

To clean food particles from the vacuum hose, flush water through hose into the jar. Remove and clean the jar before replacing.

CAUTION WHEN REMOVING THE GASKET FROM THE COVER

When removing the gasket from the cover, use a blunt object to get behind the gasket to remove it from the cover. (Do not use a sharp object. It could fracture the edge of the gasket and prevent it from sealing.) Lightly lubricate the gasket with mineral oil before installing back onto cover, this will help sealing when pulling vacuum on the drum.

MAINTENANCE

WARNING: DISCONNECT POWER BEFORE SERVICING.

NOTE: Lock and tag power disconnect to prevent application of power.

CLEANING

Properly selected and installed electric motors are capable of operating for long periods with minimal maintenance. At the same time check that electrical connections are tight. Check for any loose fasteners on drive train.

LUBRICATION

Drive chain should be lubricated periodically.

GEARBOX AND MOTOR (SEE GEARMOTOR SECTION).

VACUUM PUMP (SEE VACUUM SECTION).

LT5 TROUBLESHOOTING GUIDE

1. Make sure power cord is plugged in.
2. Turn vacuum switch on, if vacuum pump does not run:
 - A. Check outlet for power (use power tool).
3. Press the (RST/ENT) "twice", set speed dial to "50". Turn on tumbler switch, if the wheels don't rotate on machine:
 - A. Remove cabinet cover and check AC and DC fuses (AC= 12 amp) (DC = 1.25 amp)
4. Remove Electrical cover.
5. Use a "AC" volt meter set on 250V, check for power on terminal "1" and terminal "2". If no reading:
 - A. Power cord could be bad.
6. Check for power on terminal "2" and terminal "4" if no reading:
 - A. Contact block on back of tumbler on and off switch could be loose or bad.
 - B. Timer could be bad.
7. Use a "DC" volt meter set to 250V, check for power on terminal "5" and terminal "6". If no reading:
 - A. DC controller board is bad (replace)

If there is power on terminal "5" and terminal "6" the DC motor could be bad.

LT 5 VACUUM PARTS LIST

<u>REF. NO.</u>	<u>PART NO.</u>	<u>DESCRIPTION</u>	<u>QTY.</u>
1	VU688CE44	VACUUM PUMP	1
2	GATSUGF	VACUUM GAUGE	1
3	HN5346K42	FEMALE HOSE NIPPLE 1/4 - 1/4	1
4	HS26-702AM	1/4" VACUUM HOSE	3'
5	HS26-705AM	3/8" VACUUM HOSE	4'
6	TEE5372K634	MALE BRANCH TEE	1
7	HN5346K18	MALE HOSE NIPPLE 3/8 - 1/4	1
8	EL116SC	90 STREET ELBOW 1/4" NPT	3
9	PNS025B600	PIPE NIPPLE	1
10	250-36TW	TRAP BRAKET	1
11	VTAA672K	BALL TRAP	1
12	0002-49	VACUUM PLUG	1
13	OR9464K26	O-RING	1
14	BOS0AU140037	8-32X3/8" PH RHMS SS	4
15	BOS0AU160050	10-24X1/2" PH RHMS SS	3
*16	VTAJ554	TRAP BALL	1
*17	VTAJ473	TRAP FUNNEL	1
*18	VTAE274	TRAP JAR	1
19	HN5346K14	MALE HOSE NIPPLE 1/4 - 1/4	1

*NOT SHOWN

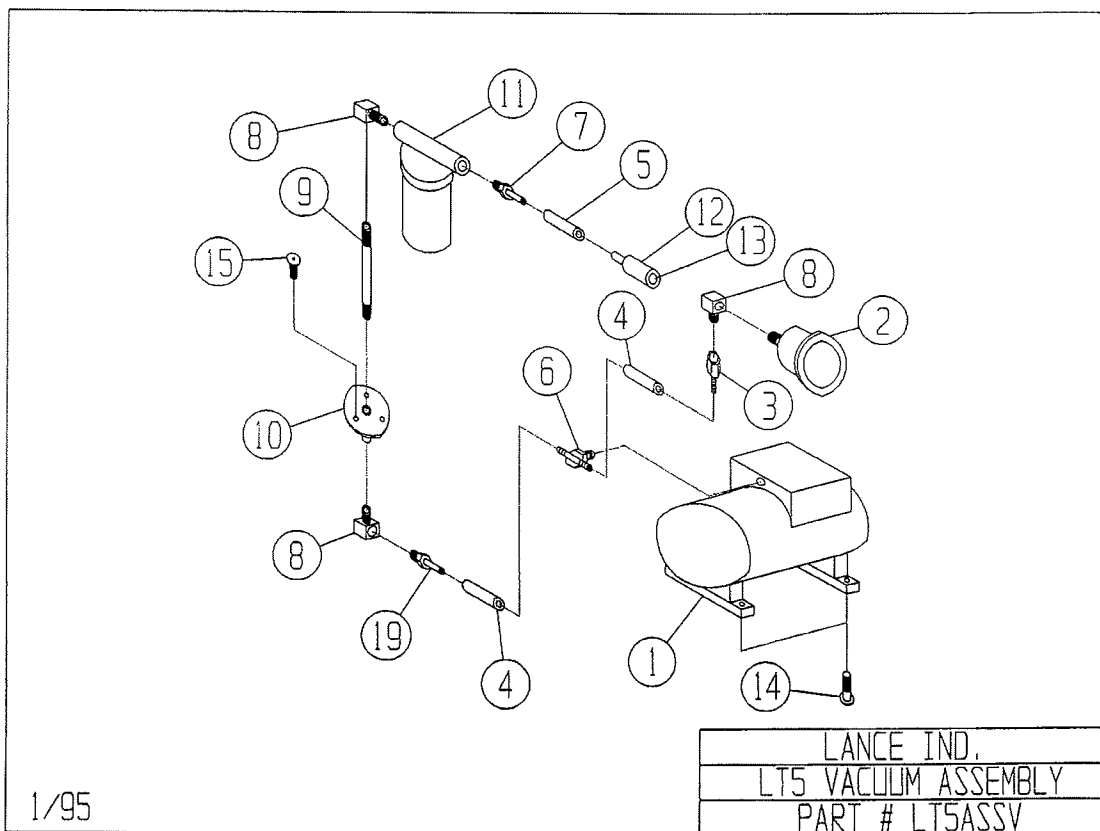

LT 5 FRAME PARTS LIST

<u>REF. NO.</u>	<u>PART NO.</u>	<u>DESCRIPTION</u>	<u>QTY.</u>
1	LT5-1	BASE	1
2	LT5-2	ENCLOSURE BACK	1
3	LT5-3B	FRONT PANEL	1
4	LT5-4	ELECTRICAL COVER	1
5	LT5-5	ENCLOSURE COVER	1
6	LT5-6	SHAFT END SUPPORT	1
7	RB9541K2	RUBBER FOOT	4
8	NU96278A009	8-32 HEX NUT W/WASHER	4
9	BOS0AA240075	3/8"-16 X 3/4" HHCS SS	3
10	BOS0AU160050	10-24X1/2" PH RHMS SS	5
11	BO90316A242	10-24X1/2" HWHMS SS	12
12	BOS0AU160100	10-24X1" PH RHMS SS	1
13	WA98449A011	#10 INTERNAL TOOTH LOCKWASHER	17
14	LT5-15	DRUM STOP	1
15	WASGA020	#10 STD. FLAT WASHER	2
16	NUS0EG16	10-24 HEX NUTS	2
17	75-011DX-02	VINYL COVER 8"X12"	1
18	BOS0AU200075	1/4"-20 x 3/4" PH RHMS SS	11
19	LALT15DP	CAUTION LABEL	1
*20	RNAHA1-420-165	1/4"-20 ALUM. RIVNUT	11
*21	LALT5PS	POWER SOURCE LABEL	1
22	WASGI025	1/4" STD. LOCKWASHER SS	11

* NOT SHOWN

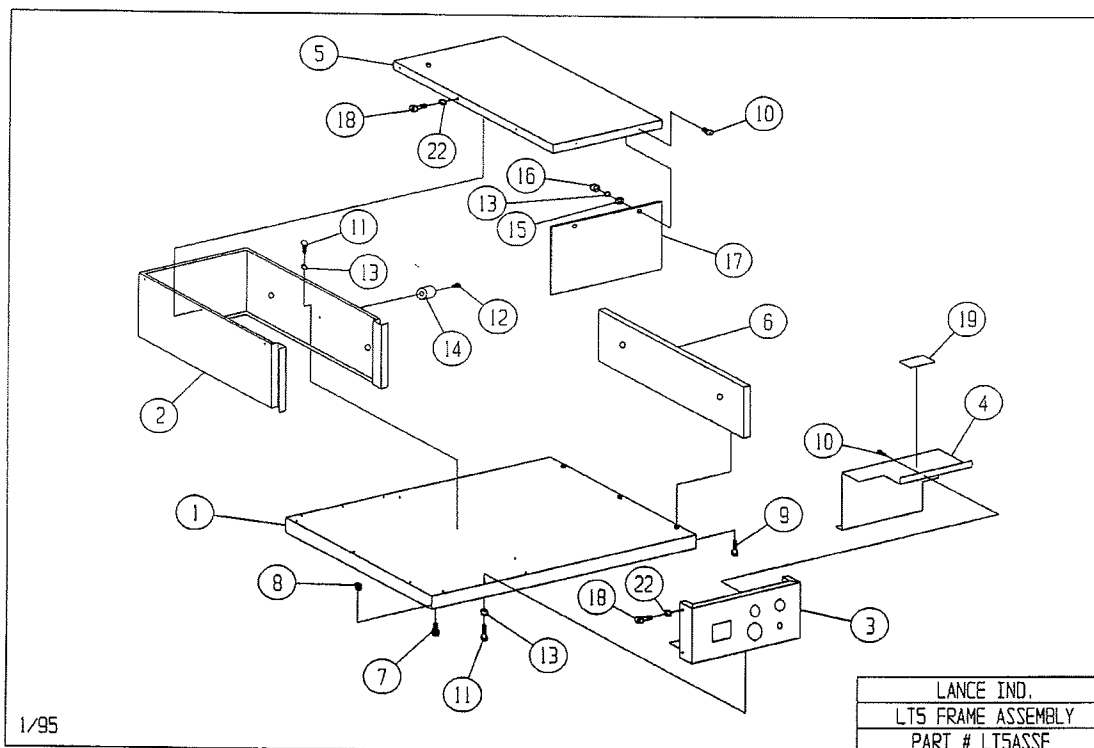

LT 5 DRIVE-TRAIN PARTS LIST

<u>REF. NO.</u>	<u>PART NO.</u>	<u>DESCRIPTION</u>	<u>QTY.</u>
1	MO4Z727	GEAR MOTOR	1
2	SP1L109	SPROCKET #4012 X 5/8	2
3	CU4X178	COUPLER 1/2"	1
4	CU4X179	COUPLER 1/2"	1
5	SI1X408	SPIDER	1
6	VI3CC03	VIBRATION ISOLATORS	3
7	RC4002000	#40 ROLLER CHAIN	2
8	LI-40	#40 CONNECTING LINK	1
9	PB1A397	PILLOW BLOCKS	2
10	SS92313A533	SOCKET SET SCREWS 1/4-20	4
11	BOS0AB200075	CARRIAGE BOLT 1/4-20 X 3/4"	4
12	NU96278A029	HEX NUT W/WASHER 1/4-20	10
13	WHRM-6-191M	WHEEL 6" 0	4
14	LT5-8	DRUM SHAFT (LONG)	1
15	LT5-9	DRUM SHAFT (SHORT)	1
16	LT5-7	WHEEL HUB	4
17	WASGA025	1/4" STD. FLAT WASHER SS	4
18	WASGI025	1/4" STD. LOCKWASHER SS	10

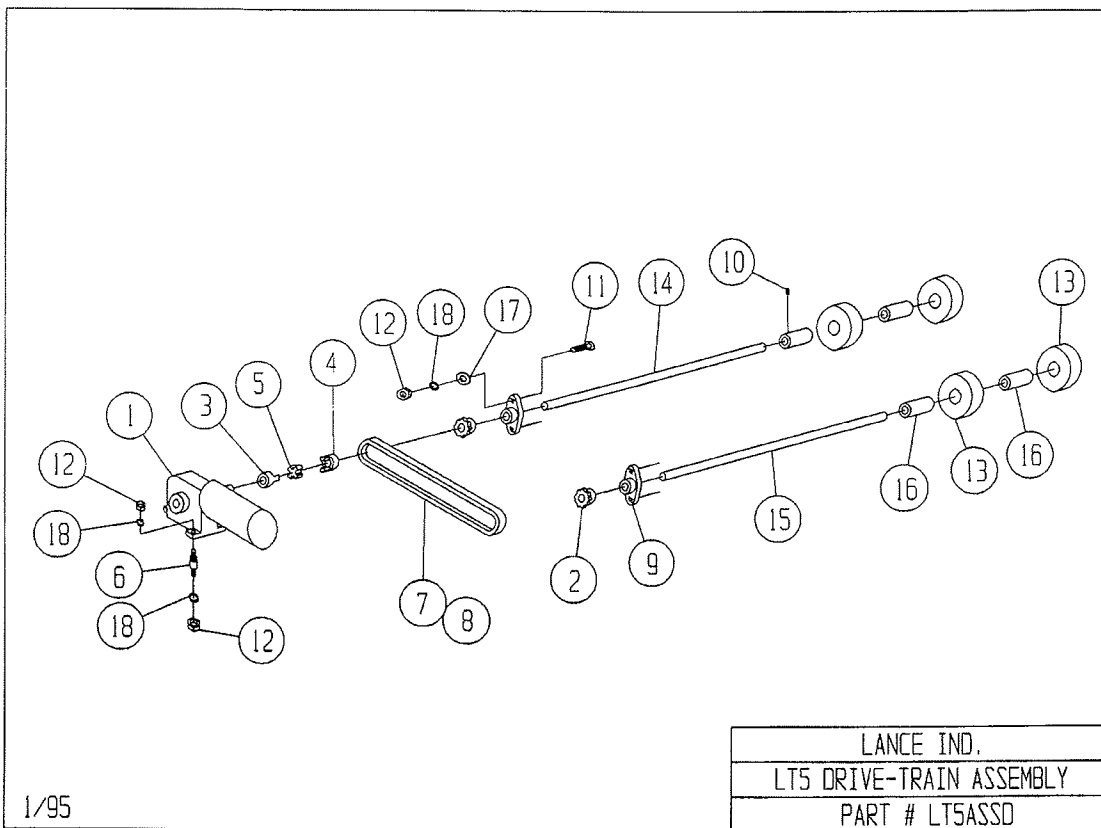

LT 5 ELECTRICAL PART LIST

<u>REF. NO.</u>	<u>PART NO.</u>	<u>DESCRIPTION</u>	<u>QTY.</u>
1	LT5FACE1	FACE PANEL	1
2	BCBC141	D.C. CONTROLLER	1
3	TM88-857-800	TIMER	1
*4	CS2W687	CORD 12 FT. LG. (W2687-70-01)	1
5	SWP9CSMDON	SELECTOR SW.	2
6	CBP9B1OVN	CONTACT BLOCK NO	3
7	TE2A691	TERMINAL SELECTION	6
8	TE2A696	TERMINAL END	1
9	BCBR0180	HP RESISTOR	1
*10	CR3217	CORD RESTRAINT W/NUT	1
*11	CT3500	NYLON CABLE TIES	10
*12	CL3608	CABLE HOLDERS	3
13	-----	-----	-
14	SK753-2352	SPEED KNOB	1
15	BOS0AU140037	BOLT 8-32X3/8" PH RHMS	6
16	LT5-17	FUSE HOLDER	1
17	FHHTB-361	FUSE HOLDER	2
*18	FU1BX44	ABC12,12 AMP FUSE	1
*19	FU6F012	AGC1 1/4,1 1/4 AMP FUSE	1
*20	LALT5FU	FUSE LABEL	1
21	CBP9B01VN	CONTACT BLOCK NC	1
22	NU70205K21	SEALING NUT	1
23	WA93650A160	SEALING WASHER	1
24	SPBC-148	5K SPEED POTENTIOMETER	1

*NOT SHOWN

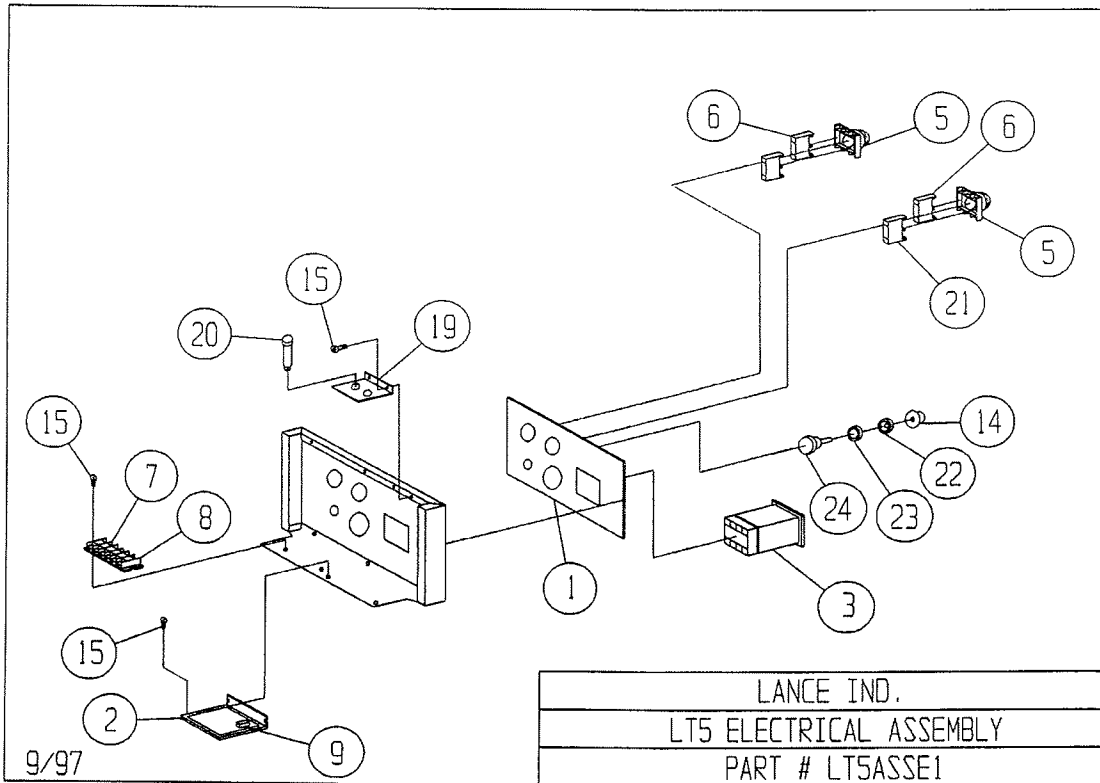

LT 5 STAINLESS DRUM PARTS LIST

<u>REF. NO.</u>	<u>PART NO.</u>	<u>DESCRIPTION</u>	<u>QTY.</u>
1	LT5-20S	STAINLESS STEEL DRUM	1
2	LT5-21S	STAINLESS STEEL COVER	1
3	LT5-12W	PADDLE	2
4	GA1330	GASKET	1
5	PV4793K52	VALVE BRASS	1
6	#600-56	NIPPLE	1

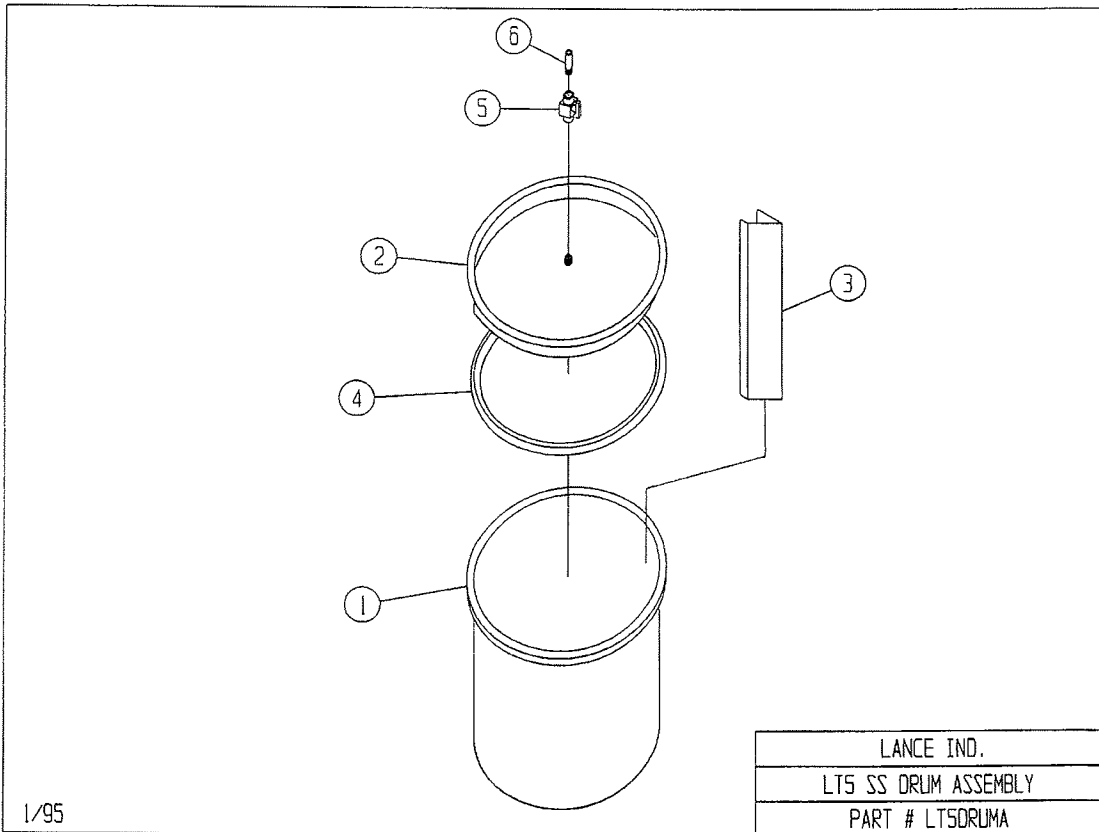

PARTS LIST - THOMAS INDUSTRIES 688CE44-59

Manufacturer/Brand: THOMAS INDUSTRIES
Model #: 688CE44-59
Description: 1/3hp Air Compressor
Additional Model Info:
Number of Parts Listed: 18

Manufacturers may change products over time. To get the right parts, be sure you have the right model. Match the **Additional Model Info** (above) to your unit's nameplate/label.

Manufacturer Part #	Description	Ref. #	Notes
607957	CONN RD, ECC, BEARING ASSY	1	
624396	PISTON CUP	2	
625776	SCREW-PISTON CUP RETAINER	3	
626380	PISTON CUP RETAINER	4	
670029	CYLINDER SLEEVE	5	
610869	HEAD	6	
623143	O-RING-HEAD GASKET	7	
625175	SCREW-HEAD	8	
621482	VALVE PLATE ASSY	9	
617177	VALVE RESTRAINT	10	
617562	VALVE KEEPER STRIP	11	
621485	VALVE FLAPPER-INTAKE & EXHAUST	12	
621632	VALVE PLATE	13	
625094	SCREW-VALVE FLAPPER	14	
623071	O-RING VALVE PLATE	15	
638281	FAN-BLACK	16	
647076	FAN GUARD	17	
620105	MOTOR END CAP	18	

Need pricing, availability, or don't see what you need? Contact Grainger Parts at 1-800-323-0620, 24 hours a day, 7 days a week

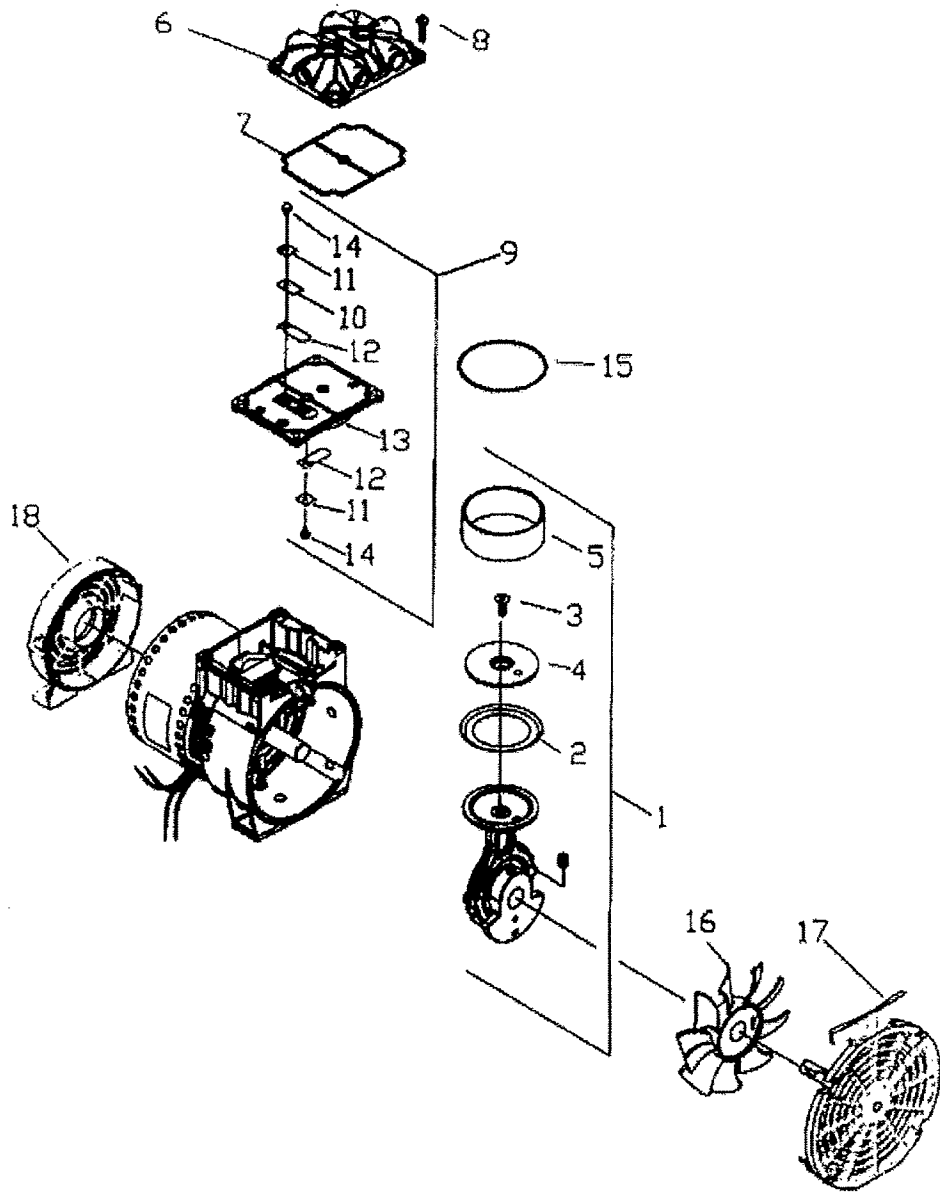



OPERATING INSTRUCTIONS & PARTS MANUAL
GEARMOTORS
 MODELS 4Z723A THRU 4Z728A

FORM 5S2664
 08090
 0590/162/1M

READ CAREFULLY BEFORE ATTEMPTING TO ASSEMBLE, INSTALL, OPERATE OR MAINTAIN THE PRODUCT DESCRIBED. PROTECT YOURSELF AND OTHERS BY OBSERVING ALL SAFETY INFORMATION. FAILURE TO COMPLY WITH INSTRUCTIONS COULD RESULT IN PERSONAL INJURY AND/OR PROPERTY DAMAGE! RETAIN INSTRUCTIONS FOR FUTURE REFERENCE.

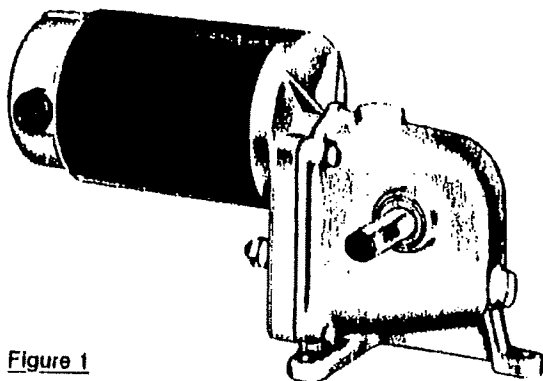

Figure 1

Description

The Dayton gearbox is constructed of zinc diecast alloy. Housing and cover are doweled for alignment. Steel helical gearing is used in the input stage for smooth operation. Remaining stages consist of steel spur gears and worm with cast iron worm gear in the final stage. Bronze sleeve bearings are used on gear journals.

General Safety Information

1. Follow all local electrical and safety codes, as well as the National Electrical Code (NEC) and the Occupational Safety and Health Act (OSHA).
2. Motor must be securely and adequately grounded. This can be accomplished by using a separate ground wire connected to the bare metal of the motor frame, or other suitable means.
3. Always disconnect power source before working on or near a motor or its connected load. If the power disconnect point is out-of-sight, lock it in the open position and tag to prevent unexpected application of power.
4. Be careful when touching the exterior of an operating motor. It may be hot enough to be painful or cause injury. With modern motors this condition is normal if operated at rated load and voltage. Modern motors are built to operate at higher temperatures.
5. Make certain that the power source conforms to the requirements of your equipment.
6. When cleaning electrical or electronic equipment, always use an approved non-flammable cleaning agent such as dry cleaning solvent.

Specifications

Motor is 90VDC permanent magnet, ball bearing, TENV for continuous duty. (10 hr. day) 40°C max. ambient, Class A insulation, externally replaceable brushes.

Motor HP and FL torque rating apply only when gearmotor is used with Dayton Model 5X412, 4Z828 or 6X165

controller or other 90VDC filtered full-wave rectified control that will give you a form factor not exceeding 1.3, or non-pulsating 90VDC power supply. Unfiltered Dayton control, Model 4Z527, 6A191, or 4Z827, may also be used with these gearmotors. FL Amps — average current read off a DC ammeter.

MODEL	FL RPM	FL TORQUE (IN-LBS)	INPUT HP	FL AMPS	POWER SUPPLY REQUIRED	GEAR RATIO
4Z723A	3.2	340	1/12	0.80	90 VDC	525:1
4Z724A	6	177	1/12	0.83	90 VDC	275:1
4Z725A	9.9	228	1/12	0.83	90 VDC	167:1
4Z726A	23.5	102	1/12	0.83	90 VDC	70:1
4Z727A	45	56	1/12	0.83	90 VDC	37:1
4Z728A	89	34	1/10	0.89	90 VDC	37:1

Dimensions

Figure 2 — Dimensions

Installation

WARNING: WHEN AN INSTALLATION INVOLVES A HOLDING OR OVERHAULING APPLICATION (SUCH AS A HOIST OR CONVEYOR), A SEPARATE MAGNETIC BRAKE OR OTHER LOCKING DEVICE SHOULD BE USED. DO NOT DEPEND ON GEAR FRICTION TO HOLD THE LOAD.

1. Gearmotor should be located in a clean and dry area with access to adequate cooling air supply. If installation is outdoors, make certain that the unit is protected from the weather.

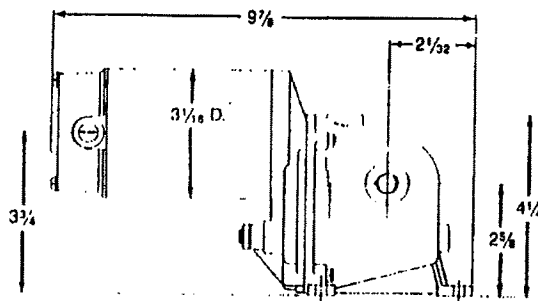
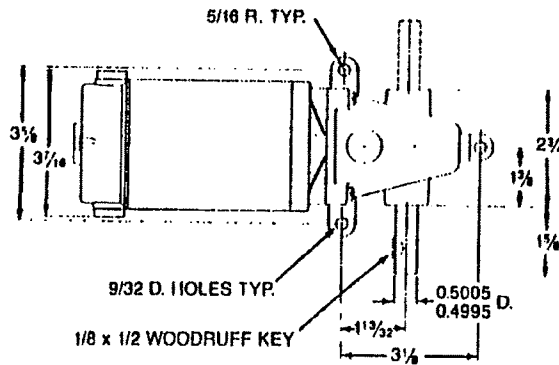
WARNING: DO NOT INSTALL IN AN EXPLOSIVE ATMOSPHERE!

2. Mount gearmotor to a rigid surface, preferably metallic, using largest bolts that will fit through the base holes.
3. Wiring connections: First determine the rotation of shaft by connecting power supply to unit. Note the direction of rotation in relationship to the power leads. If it is necessary to reverse the direction of rotation for your installation, simply reverse the leads. Disconnect power source and proceed with electrical hook up:
 - a. All wiring and electrical connections must comply with the National Electrical Code and local electrical codes in effect. In particular, refer to Article 430 (Motors, Motor Circuits and Controllers) of the NEC.

- b. Whenever possible, the motor should be powered from a separate branch circuit of adequate capacity to keep voltage drop to a minimum during starting and running. For longer runs, increase wire size in accordance with the wire selection guide shown below. Never use smaller than #14 AWG for permanent installations.

WIRE SELECTION GUIDE

#14	#10	#8	#6
50 ft	100 ft	150 ft	200 ft

- c. Motor should be grounded by use of a separate grounding conductor, connected to the motor frame. Verify that the ground wire runs to a good electrical ground such as a grounded conduit or water system.

- d. Connect the SCR Control.

Operation

Always use Dayton filtered controls Model 6X165, 4Z828 or 5X412 or unfiltered control Model 4Z527 or 4Z827 with all models of PM gearmotors listed in this manual.

Permanent magnet motors are capable of producing higher starting torques than running torques compared to other DC motor designs. PM motors are more electrically efficient than wound field DC motors and are smaller per given horsepower.

CAUTION:

- A. PM gearmotors may be operated continuously without damage, as long as nameplate amps and recommended form factor of 1.3 are not exceeded.
- B. Motor brushes need periodic inspection and replacement as wear indicates.
- C. Use of SCR controls without current limit capability can result in gear damage because the unlimited stall torques of a PM motor exceed full load torques ratings of the gearbox.
- D. PM gearmotors are not intended for instant reversing applications. PM motors can be dynamically braked and reversed at some low armature voltage (10%) but should not be plug reversed with full armature voltage. Reversing current can be no higher than locked armature current. Dayton Model 6X165 controller provides Fwd/Off/Rev switching with dynamic braking for motor protection.

WIRING MOTOR TO SCR CONTROL

The two motor leads are to be connected to terminal posts in the control marked A1 and A2 (armature). To reverse rotation (if there is no reversing switch on the control), reverse the motor lead connections.

Permanent magnet DC motor horsepower rating is determined by the motor's ability to dissipate heat. The lower the form factor of the motor and SCR control combination, the cooler the motor will run.

FORM FACTOR

Form factor is a measurement of the ripple of the supply voltage. For motors operated on rectified power, the higher the form factor number (above 1.0, unity) the greater the ripple. Ripple is undesirable because it increases motor heating as a result of energy losses in the

Operation (Continued)

motor winding and commutation, which also accelerates brush and commutator wear. Higher form factors reduce controllability of the DC motor.

ATTACHING (COUPLING) THE LOAD

NOTE: To determine output torque capacity for operating conditions, other than a normal 10 hour day and shock-free operation, multiply the rated output torque (see Specifications) by the applicable load factor listed below. Shock loads should be avoided.

LOAD FACTOR CHART

NATURE OF LOAD	OPERATING TIME		
	INTER-MITTENT	NORMAL 10-HR. DAY	CONT. 24 HRS.
Uniform	1.0	1.0	0.9
Moderate Shock	0.9	0.8	0.7

DETAILED OVERHUNG LOAD CALCULATIONS:

NOTE: Shock loads should be avoided.

- a. When connecting a load to the gearmotor output shaft, care should be taken to avoid excessive tension when either belt or chains with chain sprocket are used. Overhung loads should not exceed 50 lbs., at 1" from the bearing nose.

$$\frac{\text{Full Load Torque of Gearmotor} \times 2}{\text{Pitch Diameter of Sprocket, Pulley or Gear}} = \text{Pounds of Load on Center of Gearmotor Output Shaft}$$

Multiply pounds of load (obtained from above formula) by the correct factor listed below to determine actual overhung load in "pounds" on center of speed reducer output shaft.

DRIVE FACTORS

Sprocket	1.0
Pulley	1.5
Gear	1.25

Locate the center line of the sprocket, pulley or gear as close to the oil seal as practical to minimize overhung load and increase bearing life.

If the center line of the sprocket, pulley or gear is located more than 1" away from the oil seal, consult Dayton Electric Mfg. Co. to help determine the overhung load.

- b. On direct-coupled installations, carefully check shaft and coupling alignment as motor is being bolted down. Shim as required. Do not depend on a flexible coupling to compensate for misalignment.

Maintenance

WARNING: MAKE CERTAIN THAT THE POWER SUPPLY IS DISCONNECTED BEFORE ATTEMPTING TO SERVICE OR REMOVE ANY COMPONENTS! IF THE POWER DISCONNECT POINT IS OUT OF SIGHT, LOCK IT IN THE OPEN POSITION AND TAG TO PREVENT UNEXPECTED APPLICATION OF POWER.

BRUSH MAINTENANCE AND COMMUTATOR CARE

Dayton DC gearmotors are designed to provide up to 500 hours of brush life when operated at rated speed and load. Periodic inspection of both motor brushes

should be made to determine brush wear. When brush length reaches approximately 1/4 of an inch, Dayton approved brushes must be replaced. Reorder thru Dayton Electric Mfg. Customer Service Dept. After two (2) brush changes, consult a competent motor repair station for possible commutator refinishing.

CAUTION: To avoid brush and motor problems, replacement brushes must be Dayton brand.

LUBRICATION

This unit is lubricated for life at the factory and periodic relubrication should not be required under normal conditions.

CLEANING

Properly selected and installed electric motors are capable of operating for long periods with minimal maintenance. Periodically clean dirt accumulations preferably by vacuuming. At the same time, check that electrical connections are tight.

DISASSEMBLY

1. To disassemble gearcase, follow the same procedure as described for "reversing output shaft extension".
2. Before removing motor, remove brush cap, brush spring, and brush on each side. Remove two screws (Ref. No. 29). Field assembly (Ref. No. 16), Armature (ref. No. 17) and endbell (Ref. No. 23) Can then be removed.

REASSEMBLY

1. To reassemble gearcase, follow the same procedure as described for "reversing output shaft extension."
2. To replace armature, be sure to guide armature down thru field magnets to prevent damaging magnet wire.
3. Place field and armature back on case assembly, aligning locating key in field, with notch in cover assembly. Replace endbell aligning key in field assembly with notch in endbell. Replace two screws (Ref. No. 29) and two lockwashers (Ref. No. 30).
4. Replace brushes making sure that curvature of brushes aligns with curvature of commutator. Replace brush springs and brush caps.

WARNING: MAKE SURE GEARMOTOR IS GROUNDED BEFORE PROCEEDING. START AND STOP MOTOR TO MAKE SURE MOTOR AND GEARTRAIN IS OPERATING PROPERLY.

5. Gears can be replaced in their respective positions. Relubricate the geartrain with a heavy coat of 4 oz. of DuBois TPG grease. Make sure key is in proper location on output shaft inside output gear.
6. Replace gasket (Ref. No. 7).
7. Place new gasket in location. Replace cover casing assembly and screws.
8. Start and stop motor making sure geartrain turns freely.

NOTE: Motor full load amps rating should not be exceeded.

CAUTION: To avoid brush/motor problems, brushes must be checked periodically for wear. Brushes must be replaced when brush length reaches approximately one quarter inch. Replacement brushes must be Dayton brand. Reinspection of brushes should not exceed 300 hours.

**ORDER REPLACEMENT PARTS
BY CALLING TOLL FREE**
1-800-323-0620

Please provide following information: Address parts correspondence to:

• Model Number Dayton Electric Mfg. Co.
• Serial Number (if any) 1250 Busch Parkway
• Part Description and Number Buffalo Grove, IL 50069
as shown in Parts List.

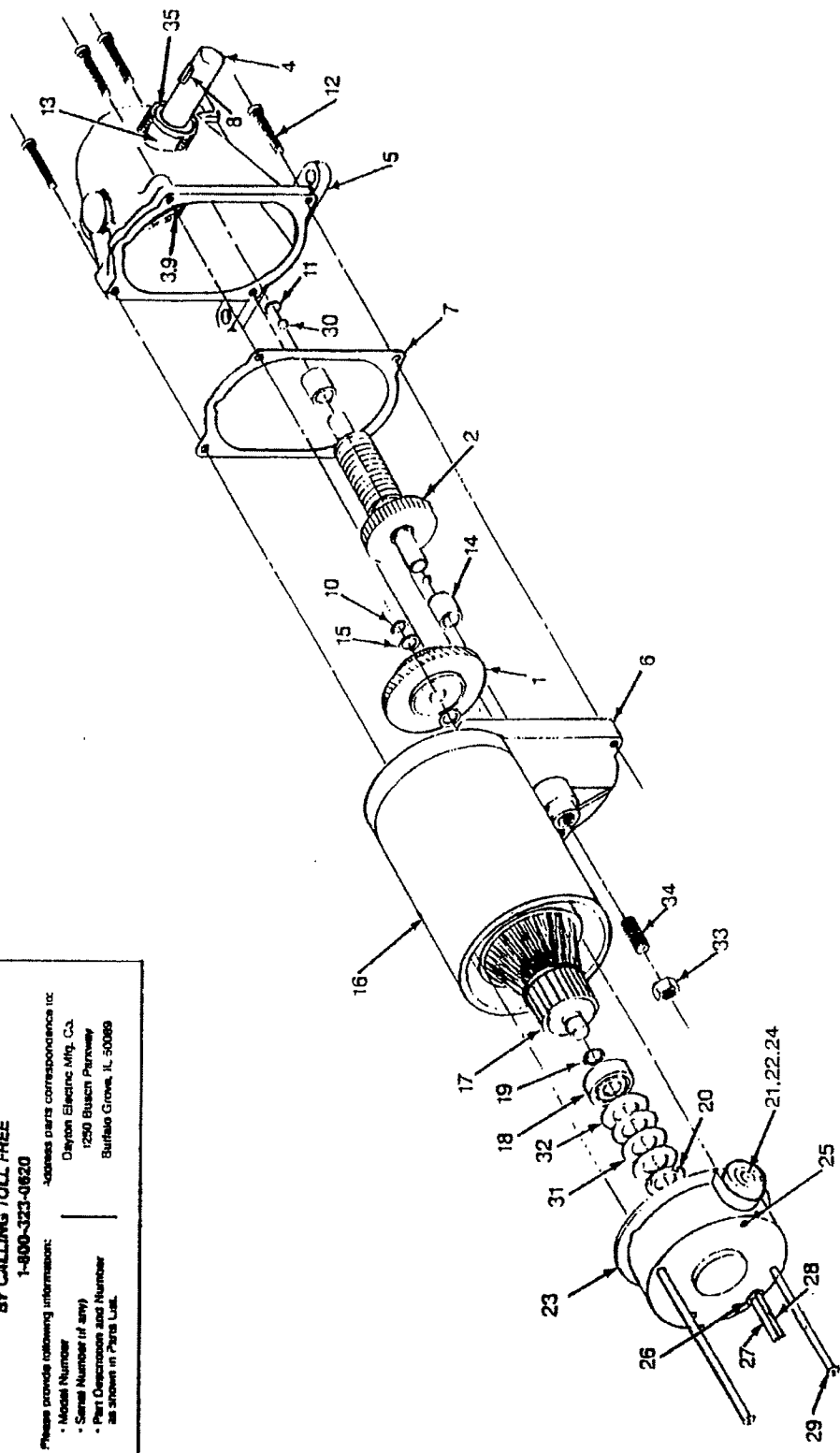

Figure 3 — Replacement Parts Illustration

Service Record

DATE	MAINTENANCE PERFORMED	REPLACEMENT COMPONENTS REQUIRED

09090

Maintenance (Continued)**REVERSING OUTPUT SHAFT EXTENSION**

If applications require that the output shaft extension be located on the opposite side of the gearmotor, proceed as follows:

1. Remove the four #10-24 gearcase assembly screws (Ref. No. 12).
NOTE: Observe position of thrust ball bearings (Ref. No. 30) and thrust plate (Ref. No. 11) on parts list drawing before proceeding with disassembly.
2. Remove gearcase assembly (Ref. No. 5) from cover assembly (Ref. No. 6).
3. Remove gear assembly (Ref. No. 2) and thrust balls (Ref. No. 31).
4. Thrust plate (Ref. No. 11) may remain in gearcase assembly boss.
5. Remove grease from gearcase assembly.
6. Remove two 1/4-28 set screws (Ref. No. 9) from output gear hub.
7. Remove output shaft (Ref. No. 4) from output gear (Ref. No. 3).
8. Remove output gear (Ref. No. 3) from gearcase assembly. Orient hub with set screw holes toward shaft extension side of gearcase assembly. Replace gear in gearcase assembly.
9. Replace shaft in output gear. (Align two spot drilled holes on output shaft with set screw holes in hub).
10. Replace and tighten two 1/4-28 set screws (Ref. No. 9) in hub.
11. Replace gear assembly (Ref. No. 2) and thrust ball.
NOTE: For ease of reassembly, place small amount of grease on each end of gear assembly and place thrust ball on gearcase end of gear assembly.
12. Relubricate gearcase assembly.
13. Replace thrust ball bearing (Ref. No. 30) on motor side of gear assembly.
14. Loosen locknut (Ref. No. 33) and back off thrust screw (Ref. No. 34) approximately two complete turns.
15. Replace cover assembly on gearcase assembly (be sure thrust balls are in place and gears are aligned before tightening gearcase assembly screws).
16. Replace and tighten gearcase assembly screws (Ref. No. 12).
17. Adjust gearing to remove excess backlash as follows:

WARNING: MAKE SURE GEARMOTOR IS GROUNDED BEFORE PROCEEDING.

- A. With motor running, tighten thrust screw with screwdriver until it sounds like motor is under load.
 - B. Back off thrust set screw just enough to make motor sound like it is running without load. Then while holding set screw in place with screwdriver, lock it by tightening the locknut.
18. Start and stop motor to check for satisfactory operation.

NOTE: Motor full load amp ratings should not be exceeded.

CAUTION: To avoid brush/motor problems, brushes must be checked periodically for wear. Reinspection of brushes should not exceed 300 hours.

Troubleshooting Chart

SYMPTOM	POSSIBLE CAUSE(S)	CORRECTIVE ACTION
Unit fails to operate	1. Blown fuse or open circuit breaker in control 2. No power 3. Defective motor	1. Replace fuse or reset circuit breaker 2. Contact power company 3. Repair or replace
Unit fails to operate when used with Dayton 6X165 controller	1. Control master speed potentiometer set near zero 2. Forward/Off/Reverse switch in off position	1. Rotate control speed potentiometer CW to 100% 2. Move switch to forward or reverse position
Unit operational but no output	1. Defective gear(s) 2. Sheared key on output shaft	1. Check and replace if necessary 2. Replace key and inspect keyway for damage
Intermittent rotation of output shaft	1. Damaged intermediate gear assembly possibly caused by shock load 2. Motor brushes worn or not making contact with commutator 3. Worn commutator	1. Replace gear and avoid shock loads 2. Replace brushes 3. Resurface or replace armature assembly
Excessive noise	1. Bearings worn 2. Belt or chain too tight 3. Overhung load (exceeds rating and causes bearing wear) 4. Motor brushes worn 5. Worn commutator	1. Replace 2. Adjust tension 3. Correct load on/or replace bearing 4. Replace 5. Resurface or replace armature assembly

LIMITED WARRANTY

DAYTON ONE-YEAR LIMITED WARRANTY. Gearmotors, Models 4Z723A thru 4Z728A, are warranted by Dayton Electric Mfg. Co. (Dayton) to the original user against defects in workmanship or materials under normal use for one year after date of purchase. Any part which is determined by Dayton to be defective in material or workmanship and returned to an authorized service location, as Dayton designates, shipping costs prepaid, will be, as the exclusive remedy, repaired or replaced at Dayton's option. For limited warranty claim procedures, see PROMPT DISPOSITION below. This limited warranty gives purchasers specific legal rights which vary from state to state.

LIMITATION OF LIABILITY. To the extent allowable under applicable law, Dayton's liability for consequential and incidental damages is expressly disclaimed. Dayton's liability in all events is limited to, and shall not exceed, the purchase price paid.

WARRANTY DISCLAIMER. Dayton has made a diligent effort to illustrate and describe the products in this literature accurately; however, such illustrations and descriptions are for the sole purpose of identification, and do not express or imply a warranty that the products are merchantable, or fit for a particular purpose, or that the products will necessarily conform to the illustrations or descriptions.

Except as provided below, no warranty or affirmation of fact, expressed or implied, other than as stated in "LIMITED WARRANTY" above is made or authorized by Dayton.

PRODUCT SUITABILITY. Many states and localities have codes and regulations governing sales, construction, installation, and/or use of products for certain purposes, which may vary from those in neighboring areas. While Dayton attempts to assure that its products comply with such codes, it cannot guarantee compliance, and cannot be responsible for how the product is installed or used. Before purchase and use of a product, please review the product application, and national and local codes and regulations, and be sure that the product, installation, and use will comply with them.

Certain aspects of disclaimers are not applicable to consumer products; e.g., (a) some states do not allow the exclusion or limitation of incidental or consequential damages, so the above limitation or exclusion may not apply to you; (b) also, some states do not allow limitations on how long an implied warranty lasts, consequently the above limitation may not apply to you; and (c) by law, during the period of this limited warranty, any implied warranties of merchantability or fitness for a particular purpose applicable to consumer products purchased by consumers, may not be excluded or otherwise disclaimed.

PROMPT DISPOSITION. Dayton will make a good faith effort for prompt correction or other adjustment with respect to any product which proves to be defective within limited warranty. For any product believed to be defective within limited warranty, first write or call dealer from whom product was purchased. Dealer will give additional directions. If unable to resolve satisfactorily, write to Dayton at address below, giving dealer's name, address, date and number of dealer's invoice, and describing the nature of the defect. Title and risk of loss pass to buyer on delivery to common carrier. If product was damaged in transit to you, file claim with carrier.

Manufactured for Dayton Electric Mfg. Co.,
5959 W. Howard St. Chicago, IL 60648

MODELS 4Z723A THRU 4Z728A

Replacement Parts List

REF. NO.	DESCRIPTION	PART NO. FOR MODEL:						QTY.
		4Z723A	4Z724A	4Z725A	4Z726A	4Z727A	4Z728A	
1	High speed gear assy.	A04786-0003	A04787-0003	A04785-0005	A04786-0003	A04787-0003	A04787-0003	1
2	Intermediate speed gear assy.	A06227-0014	A06227-0015	A06227-0018	A06227-0017	A06227-0016	A06227-0016	1
3	Output gear	H00106-0001	H00106-0001	H00106-0002	H00106-0002	H00106-0002	H00106-0002	1
4	Output shaft	J00115-0001	J00115-0001	J00115-0001	J00115-0001	J00115-0001	J00115-0001	1
5	Case assembly (Includes 2 ea. of Ref. Nos. 13 & 35. 1 ea. No. 14)	D02048-0012	D02048-0012	D02048-0012	D02048-0012	D02048-0012	D02048-0012	1
6	Cover assembly	D04624-0013	D04624-0013	D04624-0013	D04624-0013	D04624-0013	D04624-0013	1
7	Gasket	P00120-0001	P00120-0001	P00120-0001	P00120-0001	P00120-0001	P00120-0001	1
8	Output shaft key	P00423-0001	P00423-0001	P00423-0001	P00423-0001	P00423-0001	P00423-0001	1
9	Set screw (O/P-shaft)	R08F25H006P	R08F25H006P	R08F25H006P	R08F25H006P	R08F25H006P	R08F25H006P	1
10	Snap ring	R00112-0001	R00112-0001	R00112-0001	R00112-0001	R00112-0001	R00112-0001	2
11	Thrust plate	L00109-0001	L00109-0001	L00109-0001	L00109-0001	L00109-0001	L00109-0001	1
12	Cover screws	R12022-0011	R12022-0011	R12022-0011	R12022-0011	R12022-0011	R12022-0011	4
13	Output shaft bearing	L00119-0003	L00119-0003	L00119-0003	L00119-0003	L00119-0003	L00119-0003	1
14	Bearing	L00108-0001	L00108-0001	L00108-0001	L00108-0001	L00108-0001	L00108-0001	2
15	Washer	P01600-0031	P01600-0031	P01600-0031	P01600-0031	P01600-0031	P01600-0031	2
16	Field assembly	C09102-0008	C09102-0008	C09102-0008	C09102-0008	C09102-0008	C09102-0008	2
17	Armature assembly	B09121-0120	B09121-0120	B09121-0120	B09121-0120	B09121-0120	B09121-0120	1
18	Rear motor bearing	L00647-0002	L00647-0002	L00647-0002	L00647-0002	L00647-0002	L00647-0002	1
19	Snap ring	R02074-0001	R02074-0001	R02074-0001	R02074-0001	R02074-0001	R02074-0001	1
20	Finger spring	K02208-0003	K02208-0003	K02208-0003	K02208-0003	K02208-0003	K02208-0003	2
21	Brush cap	K09127-0001	K09127-0001	K09127-0001	K09127-0001	K09127-0001	K09127-0001	1
22	Brush & brush spring	K09128-0024	K09128-0024	K09128-0024	K09128-0024	K09128-0024	K09128-0024	2
23	Endbell	G08742-0027	G08742-0027	G08742-0027	G08742-0027	G08742-0027	G08742-0027	2
24	Brush holder	K09126-0004	K09126-0004	K09126-0004	K09126-0004	K09126-0004	K09126-0004	1
25	Set screw	R17F10H004P	R17F10H004P	R17F10H004P	R17F10H004P	R17F10H004P	R17F10H004P	2
26	Grommet	P10106-0001	P10106-0001	P10106-0001	P10106-0001	P10106-0001	P10106-0001	2
27	Red lead assembly	E09132-0002	E09132-0002	E09132-0002	E09132-0002	E09132-0002	E09132-0002	1
28	Black lead assembly	E09132-0001	E09132-0001	E09132-0001	E09132-0001	E09132-0001	E09132-0001	1
29	Screw, motor	R12022-0002	R12022-0002	R12022-0002	R12022-0002	R12022-0002	R12022-0002	2
30	Thrust ball bearing	L00107-0001	L00107-0001	L00107-0001	L00107-0001	L00107-0001	L00107-0001	2
31	Washer	K04656-0001	K04656-0001	K04656-0001	K04656-0001	K04656-0001	K04656-0001	2
32	Washer	K04656-0002	K04656-0002	K04656-0002	K04656-0002	K04656-0002	K04656-0002	2
33	Nut	R00981-0001	R00981-0001	R00981-0001	R00981-0001	R00981-0001	R00981-0001	1
34	Screw	R07C31H010P	R07C31H010P	R07C31H010P	R07C31H010P	R07C31H010P	R07C31H010P	1
35	Oil seal	P01694-0032	P01694-0032	P01694-0032	P01694-0032	P01694-0032	P01694-0032	2
△	Bearing kit (Includes 2 ea. of Ref. Nos. 13, 14 & 35)	D12522-0001	D12522-0001	D12522-0001	D12522-0001	D12522-0001	D12522-0001	1
△	Front motor bearing	L00647-0003	L00647-0003	L00647-0003	L00647-0003	L00647-0003	L00647-0003	1

(△) Not shown.

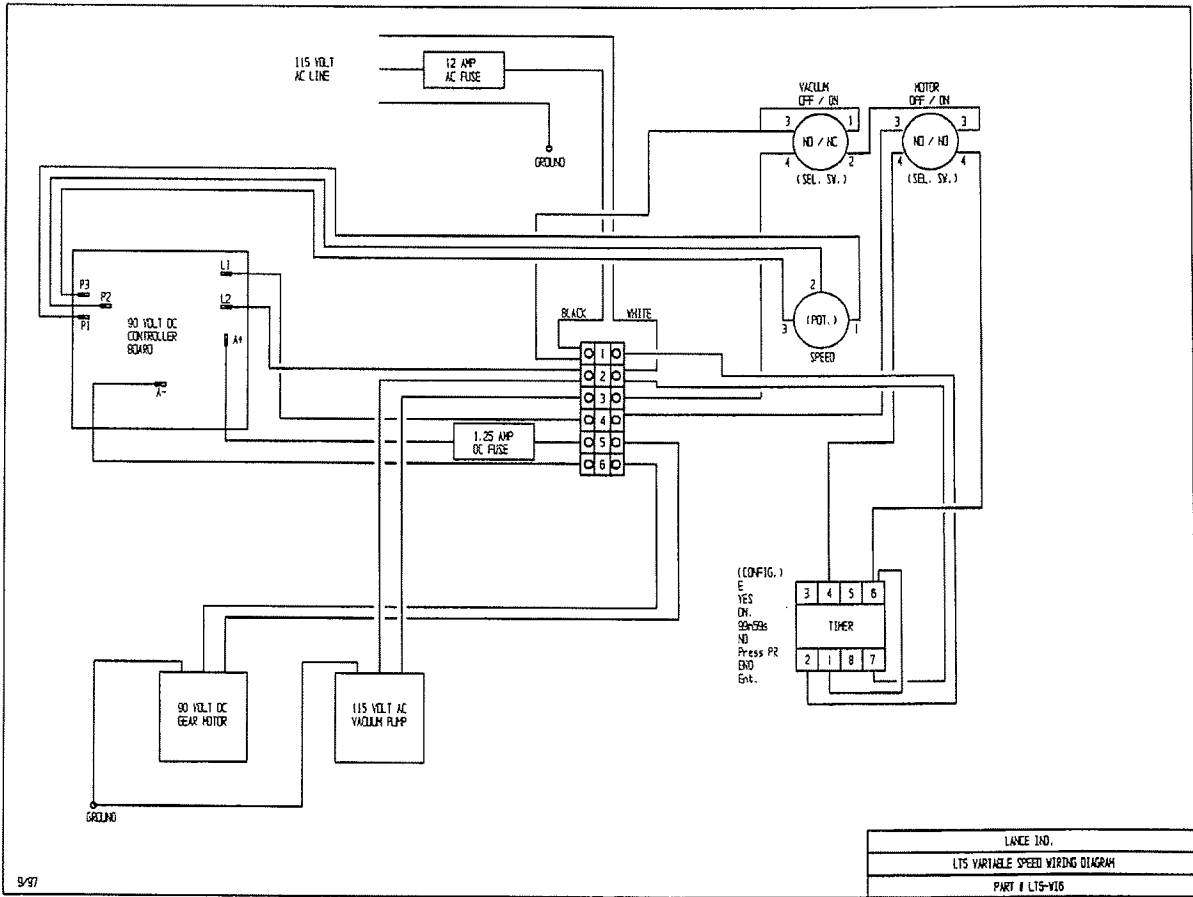

9/97