

**LT5 TABLE OF CONTENTS**

<b><u>SECTIONS :</u></b>	<b><u>PAGE NO.</u></b>
SPECIFICATION SHEET	2
INSTALLATION INSTRUCTIONS	3
OPERATING INSTRUCTIONS	4-5
CLEANING INSTRUCTIONS	6
MAINTENANCE	7
TROUBLESHOOTING GUIDE	8
NOTES	9
PARTS LIST	
- VACUUM	10-11
- FRAME	12-13
- DRIVE TRAIN	14-15
- ELECTRICAL	16-17
- STAINLESS DRUM	18-19
VACUUM PUMP	20-21
GEARMOTOR	22-24
WIRING DIAGRAM	25
TIMER MANUAL	
DC CONTROLLER MANUAL	

MACHINE MODEL NO. \_\_\_\_\_  
SERIAL NO. \_\_\_\_\_  
POWER SOURCE VOLTAGE. \_\_\_\_\_

**LT5 SPECIFICATION SHEET**

**CONSTRUCTION**

All Stainless Steel Construction with USDA approval.

**PHYSICAL DIMENSIONS**

Length	32"
Width	20"
Height	21"

**PRODUCT CAPACITY**

**STAINLESS DRUM**

Gallons	10
Liters	38
Pounds	50

**VACUUM PUMP SYSTEM**

Maximum Vacuum Liquid Trap	26"
-------------------------------	-----

**DRUM SPEED**

Variable Speed	1-20 RPM
----------------	----------

**TIMER CONTROLS**

Tumble Timer	99H 59M
--------------	---------

**ELECTRICAL**

115 Volts, 60 cycle Variable Speed Motor	.83 Amps
Vacuum Pump	3.3 Amps

**Specifications subject to change at anytime.**

## INSTALLATION INSTRUCTIONS

### **A. Unpacking**

1. Carefully remove machine and drum from the boxes.
2. Inside the drum is a box with the paddles for the drum and the vacuum jar assembly.
3. Remove the plug from the top of the tumbler.
4. Remove the cap from the pipe on the jar assembly. Screw the pipe into the hole from where the plug was removed on the tumbler and tighten securely. (There is pipe tape on the threads to seal them.)
5. Wipe down outside of the machine and drum.
6. Clean inside of the drum.

### **B. Checking Control Panel**

1. Plug the power cord into 115 Volt Receptacle with a 15 amp. Circuit breaker.

### **C. Check Vacuum Pump Control**

1. Turn on the vacuum pump. It should run.

### **D. Check Tumbler Motor Control**

1. Set variable speed control to 20.
2. Set tumbler timer to 2 minutes. (See "SETTING THE CONTROL TIMER" in the Operation Instructions section.)
3. Leave the drum off the tumbler wheels.
4. Turn on the tumbler switch - the wheels will now turn.
5. Turn the variable speed control up and down. The wheels will speed up and slow down.
6. The wheels will turn until the tumbler timer counts down to zero at which time the wheels will stop.
7. Turn off the tumbler switch.
8. Press the (RST) button on the tumbler timer.
9. The machine is now ready to use.

## OPERATING INSTRUCTIONS

### **A. Loading and Tumbling**

1. Clean the machine drum.
  2. Put the gasket on the cover.
  3. Load the product into the drum.
  4. Place the cover on the drum.
  5. Plug the machine into a 115 volt receptacle.
  6. Turn on vacuum pump.
  7. Open vacuum valve on the drum (on the drum cover).  
(Make sure the vacuum passage to the drum is clean).
  8. Push vacuum hose onto drum fitting.
  9. Run vacuum pump until 15 inches of vacuum is drawn. (Higher vacuum can be drawn if you want to.)
  10. Shut off the valve on the drum.
  11. Remove the hose.
  12. Turn off the vacuum pump.
  13. Set the drum on machine wheels (with the cover toward control panel).
  14. Set the tumbler timer to the desired time.
  15. Set the variable speed knob to the desired speed.
  16. Make sure the vacuum hose is disconnected.
  17. Turn on the motor switch. The drum will now rotate until the tumbler timer runs down to zero.
  18. To restart the tumbling process after the time has timed down to zero. Turn the motor switch off.
  19. Press the (RST) button on the timer, the timer will reset to its preset time.
  20. Turn the motor switch on to start the time cycle again.
- \* It can be stopped at any time by turning off the motor switch.
- \* To restart the machine, turn on the motor start switch. It will run for the time remaining on the timer.

### **B. Unloading the Drum**

#### **Manual Unloading**

1. Remove the drum from the machine and set on a flat surface.
2. Open the vacuum valve on the cover to release the vacuum.
3. Remove the cover.
4. Unload the drum.

## SETTING THE CONTROL TIMER

### **Direct start continuous tumbling**

1. Press (RST) button on the tumbler timer.
  2. Set the set-point on the tumbler timer for total tumbling time (time required for the drum to rotate.)
  3. To set the time on the tumbler timer, press the left arrow button on the timer, notice the far right position on the lower display is blinking.
  4. Use the UP or DN., arrow button to change the value of this number. (The timer is set for HR-min.)
  5. Use the left arrow button to change to a new position, then repeat step #4.(Do this for each position).
  6. When all the values are entered, press the (MD)button on the timer.(This will enter the time into memory).
  7. Press the (RST) button to change the upper values on the timer.
  8. The tumbler timer is ready to run.
  9. Turn on the tumbler switch to begin the cycle.
- \* The tumbler can be stopped by turning the motor switch off. The tumbler timer will maintain it's time.
- \* To restart the tumbler turn the motor switch on. The tumbler timer will continue from where it left off. Pressing the reset button on the tumbler timer in the middle of a tumbling cycle will reset the timer to the preset time setting.

## **CLEANING INSTRUCTIONS**

### **CLEANING YOUR MACHINE**

Remove lid and rinse. The drum can be cleaned with your standard cleaning solution in a sink.

### **FLUSHING VACUUM VALVE ON COVER**

Open valve and thoroughly flush with water. This must be done between loads, before pulling vacuum on the drum. If the valve is not cleaned properly, food particles will be drawn into the vacuum hose.

### **CLEANING VACUUM HOSE**

To clean food particles for the vacuum hose, flush water through hose into the jar. Remove and clean the jar before replacing.

### **CAUTION WHEN REMOVING THE GASKET FROM THE COVER**

When removing the gasket from the cover, use a blunt object to get behind the gasket to remove it from the cover. (Do not use a sharp object. It could fracture the edge of the gasket and prevent it from sealing.) Lightly lubricate the gasket with mineral oil before installing back onto cover, this will help sealing when pulling vacuum on the drum.

## MAINTENANCE

**WARNING: DISCONNECT POWER BEFORE SERVICING.**

**NOTE:** Lock and tag power disconnect to prevent application of power.

### **CLEANING**

Properly selected and installed electric motors are capable of operating for long periods with minimal maintenance. At the same time check that electrical connections are tight. Check for any loose fasteners on drive train.

### **LUBRICATION**

Drive chain should be lubricated periodically.

**GEARBOX AND MOTOR** (SEE GEARMOTOR SECTION).

**VACUUM PUMP** (SEE VACUUM SECTION).

## LT5 TROUBLESHOOTING GUIDE

1. Make sure power cord is plugged in.
2. Turn vacuum switch on, if vacuum pump does not run:
  - A. Check outlet for power (use power tool).
3. Press the (RST) "twice", set speed dial to "50". Turn on tumbler switch, if the wheels don't rotate on machine:
  - A. Remove cabinet cover and check AC and DC fuses (AC= 12 amp) (DC = 1.25 amp)
4. Remove Electrical cover.
5. Use a "AC" volt meter set on 250V, check for power on terminal "1" and terminal "2". If no reading:
  - A. Power cord could be bad.
6. Check for power on terminal "2" and terminal "4" if no reading:
  - A. Contact block on back of tumbler on and off switch could be loose or bad.
  - B. Timer could be bad.
7. Use a "DC" volt meter set to 250V, check for power on terminal "5" and terminal "6". If no reading:
  - A. DC controller board is bad (replace)

If there is power on terminal "5" and terminal "6" the DC motor could be bad.



## NOTES

**LT5 VACUUM PARTS LIST**

<b><u>REF. NO.</u></b>	<b><u>PART NO.</u></b>	<b><u>DESCRIPTION</u></b>	<b><u>QTY.</u></b>
1	VU688CE44	VACUUM PUMP	1
2	VG203L-204A	VACUUM GAUGE	1
3	HN5346K42	FEMALE HOSE NIPPLE 1/4 - 1/4	1
4	HS26-702AM	1/4" VACUUM HOSE	3'
5	HS26-705AM	3/8" VACUUM HOSE	4'
6	TEE5372K634	MALE BRANCH TEE	1
7	HN5346K18	MALE HOSE NIPPLE 3/8 - 1/4	1
8	EL116SC	90 STREET ELBOW 1/4" NPT	3
9	PNS025B0600	PIPE NIPPLE	1
10	250-36TW	TRAP BRACKET	1
11	VTAA672K	BALL TRAP	1
12	0002-49	VACUUM PLUG	1
13	OR9464K26	O-RING	1
14	BOS0AU140037	8-32X3/8" PH RHMS SS	4
15	BOS0AU160050	10-24X1/2" PH RHMS SS	3
*16	VTAJ554	TRAP BALL	1
*17	VTAJ473	TRAP FUNNEL	1
*18	VTAE274	TRAP JAR	1
19	HN5346K14	MALE HOSE NIPPLE 1/4 - 1/4	1
*20	GS9423K31	GAUGE SEAL	1

\*NOT SHOWN

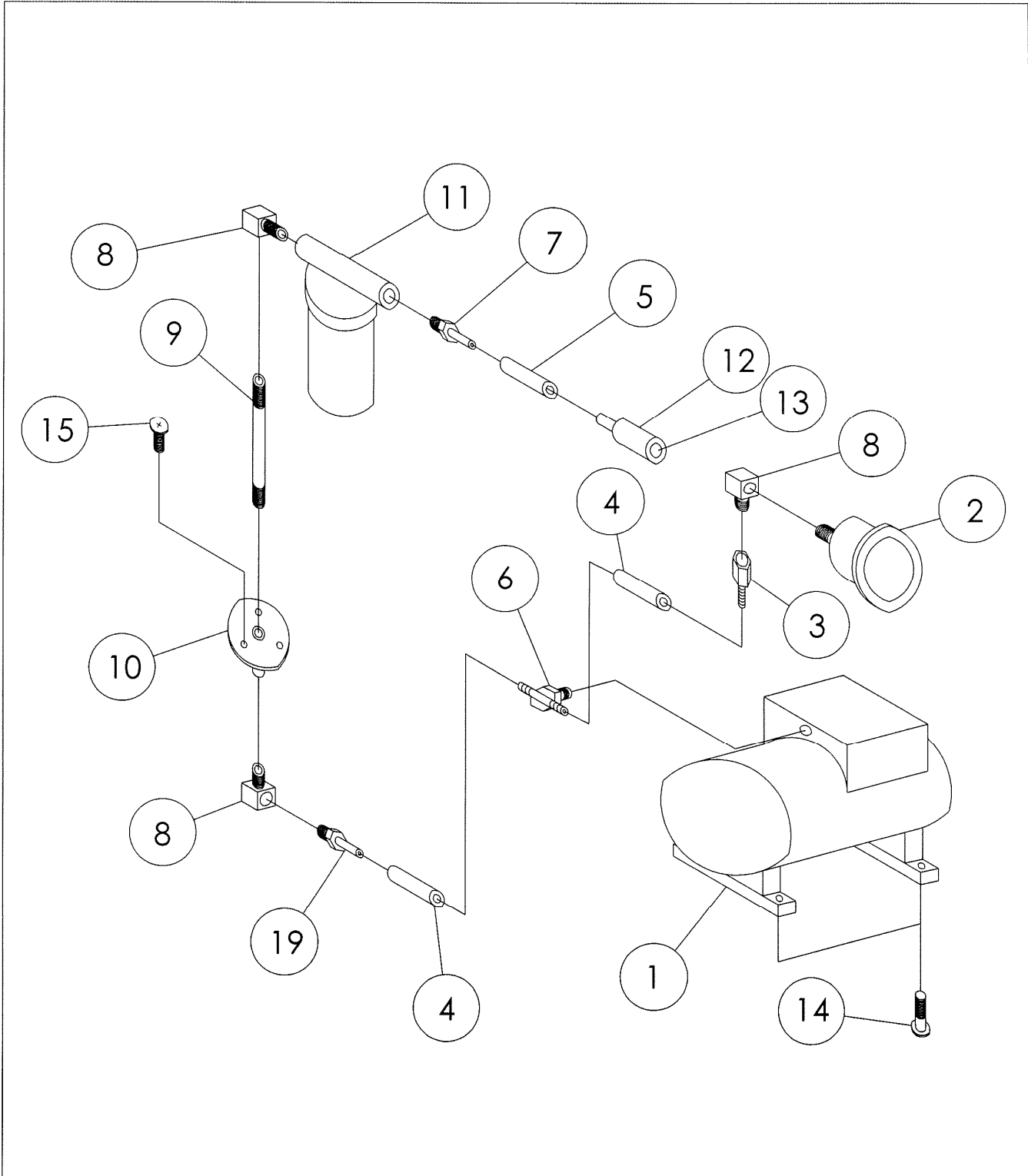

LANCE IND.
LT5 VACUUM ASSEMBLY
PART # LT5ASSV

1/95

**LT5 FRAME PARTS LIST**

<u>REF. NO.</u>	<u>PART NO.</u>	<u>DESCRIPTION</u>	<u>QTY.</u>
1	LT5-1	BASE	1
2	LT5-2	ENCLOSURE BACK	1
3	LT5-3B	FRONT PANEL	1
4	LT5-4	ELECTRICAL COVER	1
5	LT5-5	ENCLOSURE COVER	1
6	LT5-6	SHAFT END SUPPORT	1
7	RB9541K2	RUBBER FOOT	4
8	NU96278A009	8-32 HEX NUT W/WASHER	4
9	BOS0AA240075	3/8"-16 X 3/4" HHCS SS	3
10	BOS0AU160050	10-24X1/2" PH RHMS SS	5
11	BO90316A242	10-24X1/2" HWHMS SS	12
12	BOS0AU160100	10-24X1" PH RHMS SS	1
13	WA98449A011	#10 INTERNAL TOOTH LOCKWASHER	17
14	LT5-15	DRUM STOP	1
15	WASGA020	#10 STD. FLAT WASHER	2
16	NUS0EA16	10-24 HEX NUTS	2
17	75-011DX-02	VINYL COVER 8"X12"	1
18	BOS0AU200075	1/4-20 x 3/4" PH RHMS SS	11
19	LALT15DP	CAUTION LABEL	1
*20	RNAHA1-420-165	1/4-20 ALUM. RIVNUT	11
*21	LALT5PS	POWER SOURCE LABEL	1
22	WASGI025	1/4" STD. LOCKWASHER SS	11

\* NOT SHOWN

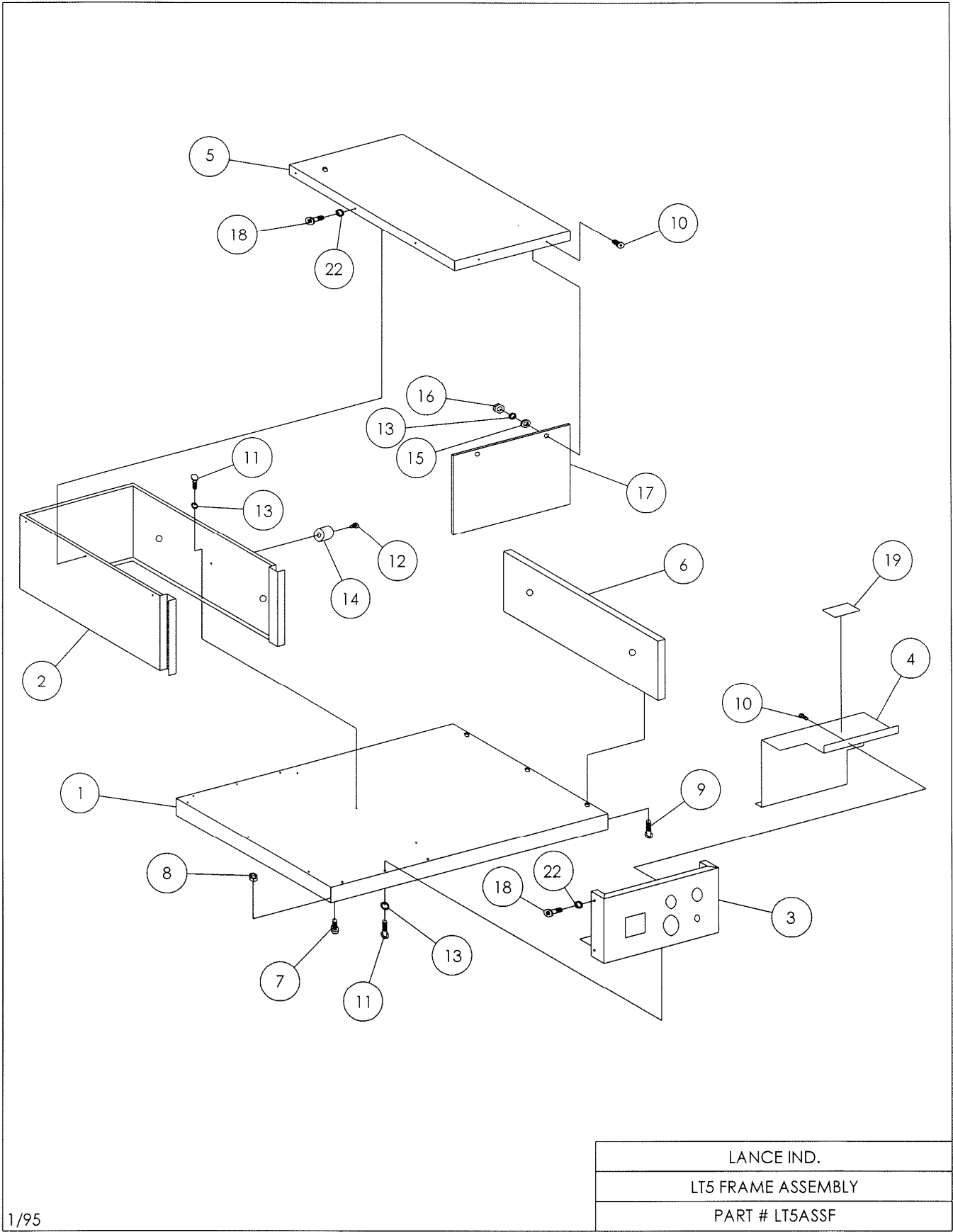

**LT5 DRIVE-TRAIN PARTS LIST**

<b><u>REF. NO.</u></b>	<b><u>PART NO.</u></b>	<b><u>DESCRIPTION</u></b>	<b><u>QTY.</u></b>
1	MO1LRB4	GEAR MOTOR	1
2	SP1L109	SPROCKET #4012 X 5/8	2
3	CU4X178	COUPLER 1/2"	1
4	CU4X179	COUPLER 5/8"	1
5	SI1X408	SPIDER	1
6	VI3CCO3	VIBRATION ISOLATORS	3
7	RC403000	#40 ROLLER CHAIN (30"Lg.)	1
8	LI-40	#40 CONNECTING LINK	1
9	PB1A397	PILLOW BLOCKS	2
10	SS92313A533	SOCKET SET SCREWS 1/4-20	4
11	BOS0AB200075	CARRIAGE BOLT 1/4-20 X 3/4"	4
12	NU96278A029	HEX NUT W/WASHER 1/4-20	10
13	WHRM-6-191M	WHEEL 6" 0	4
14	LT5-8	DRUM SHAFT (LONG)	1
15	LT5-9	DRUM SHAFT (SHORT)	1
16	LT5-7	WHEEL HUB	4
17	WASGA025	1/4" STD. FLAT WASHER SS	4
18	WASGI025	1/4" STD. LOCKWASHER SS	10

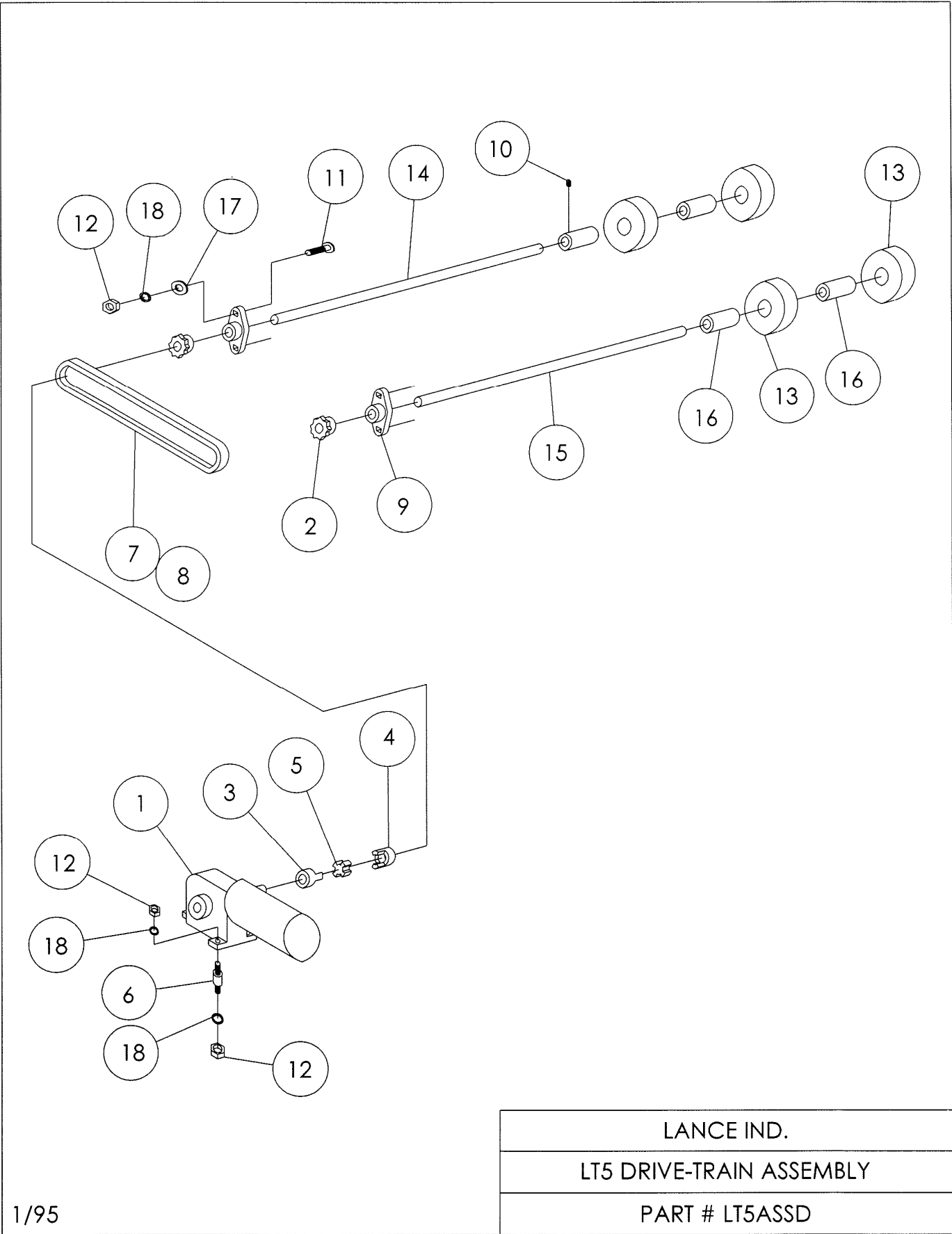

1/95

**LT5 ELECTRICAL PARTS LIST**

<b><u>REF. NO.</u></b>	<b><u>PART NO.</u></b>	<b><u>DESCRIPTION</u></b>	<b><u>QTY.</u></b>
1	LT5FACE1	FACE PANEL	1
2	BCBC141	D.C. CONTROLLER	1
3	TMCT4S	TIMER AUTONICS	1
*4	CS2W687	CORD 12 FT. LG. (W2687-70-01)	1
5	SWP9CSMDON	SELECTOR SW.	2
6	CBP9B1OVN	CONTACT BLOCK NO	2
7	TE2A691	TERMINAL SELECTION	6
8	TE2A696	TERMINAL END	1
9	BCBR0180	HP RESISTOR	1
*10	CR3217	CORD RESTRAINT W/NUT	1
*11	CT3500	NYLON CABLE TIES	10
*12	CL3608	CABLE HOLDERS	3
13	-----	-----	-
14	SK753-2352	SPEED KNOB	1
15	BOS0AU140037	BOLT 8-32X3/8" PH RHMS	6
*16	LALT5FU	FUSE LABEL	1
*17	FU6F012	AGC1-1/4, 1-1/4 AMP FUSE	2
*18	FU1BX44	ABC12,12 AMP FUSE	1
19	LT5-17	FUSE HOLDER BRKT.	1
20	FHHTB-36I	FUSE HOLDER	1
21	CBP9B01VN	CONTACT BLOCK NC	1
22	NU70205K21	SEALING NUT	1
23	WA93650A160	SEALING WASHER	1
24	SPBC-148	5K SPEED POTENTIOMETER	1
*25	CBP9B11VN	CONTACT BLOCK-N.O./N.C.	1

\*NOT SHOWN



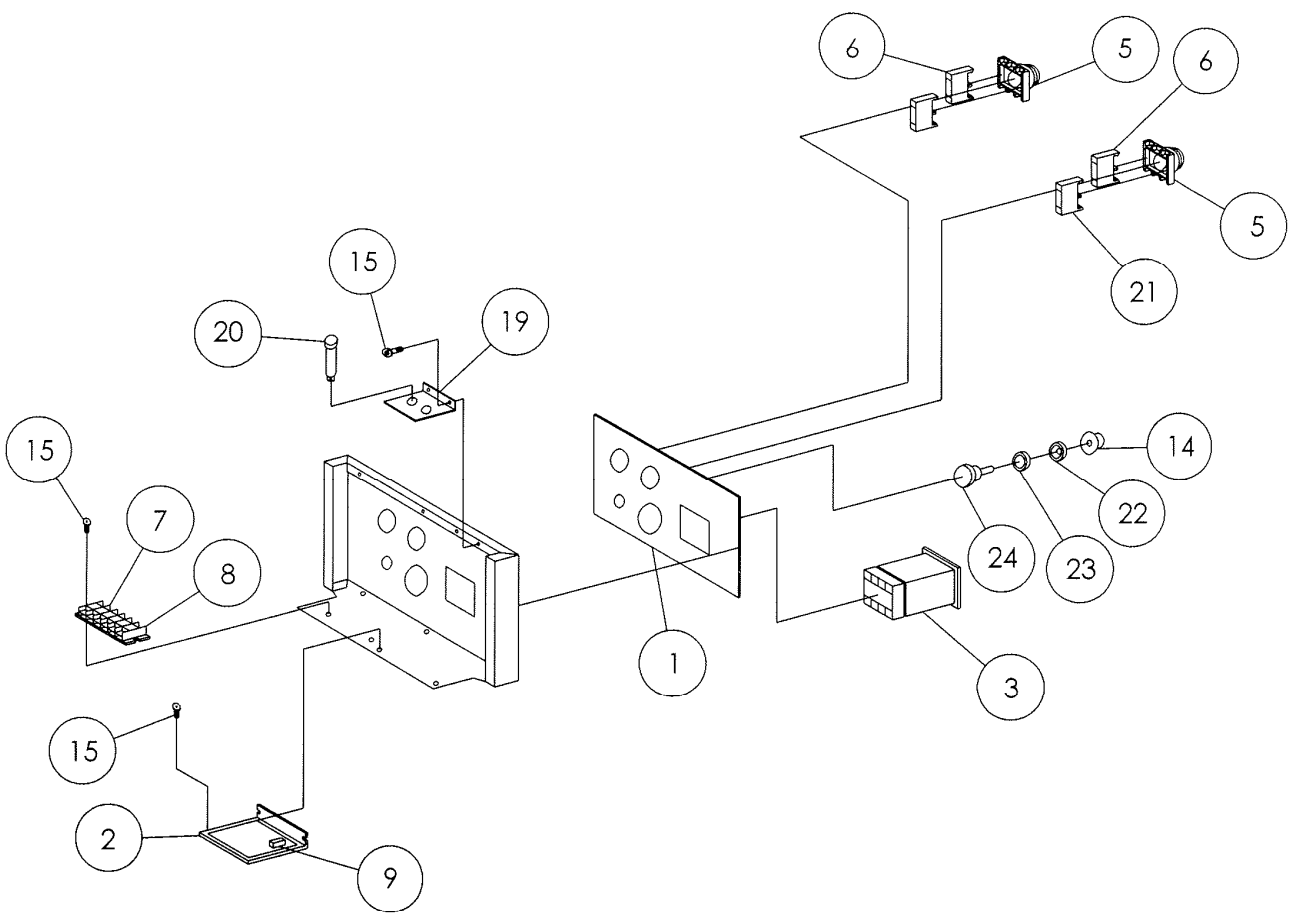

LANCE IND.
LT5 ELECTRICAL ASSEMBLY
PART # LT5ASSE1

9/97

**LT5 STAINLESS DRUM PARTS LIST**

<b><u>REF. NO.</u></b>	<b><u>PART NO.</u></b>	<b><u>DESCRIPTION</u></b>	<b><u>QTY.</u></b>
1	LT5-20S	STAINLESS STEEL DRUM	1
2	LT5-21S	STAINLESS STEEL COVER	1
3	LT5-12W	PADDLE	2
4	GA1330	GASKET	1
5	PV4793K52	VALVE BRASS	1
6	#600-56	NIPPLE	1

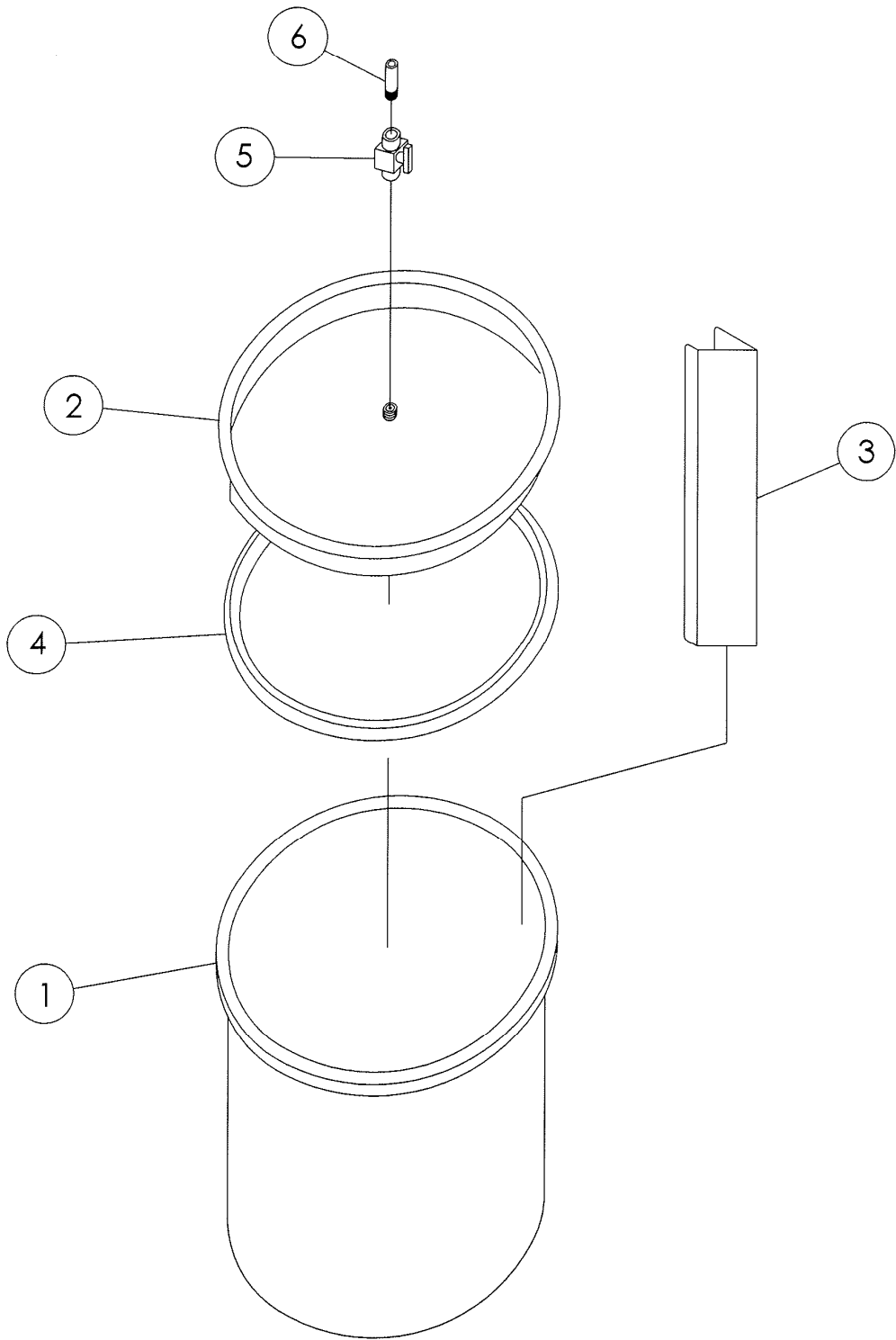

LANCE IND.
LT5 SS DRUM ASSEMBLY
PART # LT5DRUMA

1/95



A Gardner Denver Product

1419 ILLINOIS AVE., SHEBOYGAN, WI 53082  
(920) 457-4891 www.rtpumps.com

# MODEL NUMBER: 688CE22, 688CE44, 688CGHI22, 688CWW44, 688CGHI32, 688CGHI44, 688CS44

Read and understand the follow information and instructions included with this product before using. This information is for your safety and to prevent damage to this product.

**CAUTION: To reduce risk of electrical shock..**

1. Do not disassemble. Disassembly or attempted repairs if accomplished incorrectly can create electrical shock hazard. Refer servicing to qualified service agencies only.
2. If this plug is supplied with a three pronged plug, connect unit to a properly grounded outlet only.

**WARNING: To reduce risk of electrocution ...**

1. This product should never be left unattended when plugged in.
2. Always unplug this product immediately after using and store in dry place.
3. Do not use this product in or near area where it can fall or be pulled into water or other liquids.
4. Do not reach for this product if it has fallen into liquid. Unplug immediately.
5. Never operate this product outdoors in the rain or in a wet area.

**DANGER: To reduce risk of explosion or fire...**

1. Do not use this product in or near explosive atmospheres or where aerosol (spray) products are being used.
2. Do not pump anything other than atmospheric air.
3. Do not pump combustible liquids or vapors with this product or use in or near an area where flammable or explosive liquids or vapors may exist.
4. Do not use this product near flames.

**CAUTION: To prevent Injury...**

1. Close supervision is necessary when this product is used near children or invalids. Never allow children to operate unit.
2. Never operate this product if it has a damaged cord or plug, if it is not working properly, if it has been dropped or damaged or if it has fallen into water. Return the product to a service center for examination and repair.
3. Keep the cord away from heated surfaces.
4. Never block any air openings (inlet) of this product or place it on a soft surface where the openings may be blocked. Keep all air openings free of lint, dirt and other foreign objects.
5. Never use while sleeping or drowsy.
8. Never drop or insert fingers or any other object into openings.
7. Do not operate this product where oxygen is being administered.
8. This unit may be thermally protected and can automatically restart when the protector resets. Always disconnect power source before servicing.
9. Wear safety glasses or goggles when operating this product.
10. Use only in well ventilated areas.
11. Do not use any tools or attachments without first determining maximum air pressure for that tool or attachment.
12. Never point any air nozzle or air sprayer toward another person or any part of the body.
13. All electrical products generate heat. To avoid serious burns never touch unit during or immediately after operation.

Failure to observe the above safety precautions could result in severe bodily injury, including death in extreme cases.

## SAVE THESE INSTRUCTIONS



Warning: Thomas compressors are precision-made, and carefully assembled and wired. Do not disassemble or attempt to repair this product. Repair should be performed by qualified service personnel only.



### IMPORTANT NOTICE TO PURCHASER: WARRANTY AND EXCLUSIVE REMEDIES

Thomas finished OEM products, when properly installed and under normal conditions of use, are warranted by Thomas to be free from defects in material and workmanship at time of shipment. Warranty claims regarding OEM limited products must be asserted within 18 months (the "warranty period" ) from date of manufacture encoded on the product (unless otherwise agreed in writing or specified in a Thomas OEM Quotation). The customer's exclusive remedy against Thomas for a warranty claim or otherwise, shall be limited to repair or replacement of the subject OEM finished product if it is shown to have been defective in material and workmanship at time of shipment, and then only if the claim is asserted during the warranty period. Thomas maximum liability under this exclusive remedy shall never exceed the cost of the subject product and Thomas reserves the right, at its sole discretion, to refund the purchase price in lieu of repair or re placement. Except for such warranty and exclusive remedy as stated (and except for the express warranty of title) THOMAS DISCLAIMS ALL OTHER WARRANTIES WITH RESPECT TO ITS OEM FINISHED PRODUCTS, WHETHER IMPLIED, AND SPECIFICALLY DISCLAIMS THE IMPLIED WARRANTIES OF MERCHANTABILITY AND FITNESS FOR A PARTICULAR PURPOSE. IN NO EVENT SHALL THOMAS BE LIABLE TO CUSTOMER OR THIRD PARTIES

IN WARRANTY, CONTRACT, NEGLIGENCE, STRICT LIABILITY, OR OTHERWISE, FOR ANY DAMAGES, WHETHER INCIDENTAL OR CONSEQUENTIAL, WHICH ARE ALLEGED TO HAVE BEEN CAUSED BY ONE OR MORE OF OUR PRODUCTS BEYOND THE COST TO THE CUSTOMER OF THE SUBJECT PRODUCT OR PRODUCTS. THE EXCLUSIVE REMEDY FOR ANY CLAIM HAVING BEEN LIMITED TO REPAIR OR REPLACEMENT AS AFORESAID.

Because Thomas OEM warranties and remedies extend only to our direct customers, the customer is not authorized TO extend warranties on our behalf to anyone. Unauthorized extensions of warranties by the customer shall remain customer's responsibility.

CUSTOMER IS RESPONSIBLE FOR DETERMINING THE SUITABILITY OF OUR PRODUCTS FOR CUSTOMER'S USE OR RESALE, OR FOR INCORPORATING THEM INTO OBJECTS OR FOR APPLICATIONS WHICH CUSTOMER DESIGNS, ASSEMBLES, CONSTRUCTS OR MANUFACTURES.

# DRAWING AND PARTS LIST

* Con Rod, Ecc, Slv & Brg Assy			
Item	Part No.	Description	Qty
1	666509	.22 Stroke	1
1	666469	.32 Stroke	1
1	666459	.44 Stroke	1

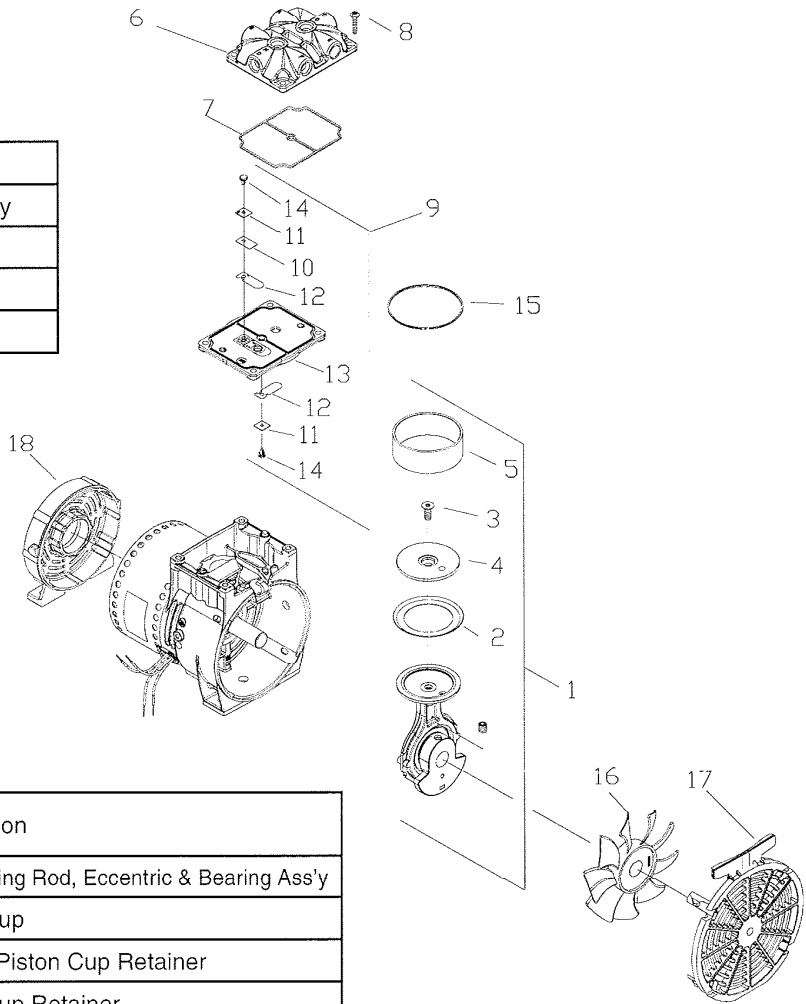

Item No.	Part No.	Qty. Per Ass'y	Qty. Per Unit	Description
1	See Chart	--	1	*Connecting Rod, Eccentric & Bearing Ass'y
2	624396	1	1	Piston Cup
3	625180	1	1	Screw - Piston Cup Retainer
4	626397	1	1	Piston Cup Retainer
5	670031	1	1	Cylinder Sleeve
6	610869	--	1	Head
7	623143	--	1	O-Ring - Head Gasket
8	625175	--	4	Screw - Head
9	621482	--	1	Valve Plate Assembly
10	617177	1	1	Valve Restraint
11	617562	1	2	Valve Keeper Strip
12	621485	1	2	Valve Flapper - Intake & Exhaust
13	621632	1	1	Valve Plate
14	625094	1	2	Screw - Valve Flapper
15	623071	--	1	O-Ring Valve Plate
16	638281	--	1	Fan - Gray
17	647076		1	Fan Guard
18	620105		1	Motor End Cap

Read the Gearmotor Installation and Maintenance Information Manual 85708 included with this product before installing or performing maintenance. Read this document carefully before attempting to disassemble, reassemble, operate or maintain the product described. Protect yourself and others by observing all safety information. Failure to comply with instructions could result in personal injury and/or property damage! Retain instructions for future reference.

# Dayton® 90 VDC Permanent Magnet Gearmotors

Refer to Form 85708 for Safety and Installation, Operation and Maintenance Instructions and Warranty Information

**⚠ WARNING** Make certain power supply is disconnected before attempting to service or remove any components! If the power disconnect point is out-of-sight, lock it in the open position and tag to prevent unexpected application of power.

**⚠ CAUTION** These gearmotors are gear limited in strength. The motor has the ability to produce an output torque level considerably above the nameplated output torque rating. Operation of the unit at torque levels above nameplated rating will damage gearing.

## Wiring Diagram

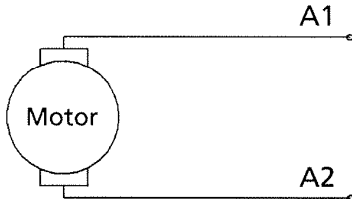

## Disassembly Instructions

1. Remove any burrs or sharp edges from the output shaft, especially at the keyway, by filing. This practice will avoid damaging the grease seal or output shaft when the gearcase cover is removed.
2. Remove the screws from the face of the gearcase.
3. With the unit resting with the output shaft up, remove the cover.

4. With the gearcase now disassembled, the gears can be removed.
5. The oil seal can be removed by gently prying it from the front of the gearcase. If it is an O-ring type, it removes easily with a small screwdriver.

## Reassembly Instructions

1. Place field and armature assembly back on cover assembly, aligning locking key in field with notch in cover assembly. Replace endbell aligning key in field assembly with notch in endbell. Replace screws and tighten.
2. Clean out gearcase completely and replace gears. Now replace lubricant into gearcase. Never mix different types of lubricants.  
5 oz. 4ZF46

3. If oil seal was removed, clean cavity seat and insert seal. If unit has gasket, replace with new one.
4. Place cover over mating gearcase half, insert screws and tighten.
5. Start and stop unit several times to ensure no parts are binding.

**⚠ CAUTION** To avoid brush/motor problems, brushes must be checked periodically for wear. Brushes must be replaced when wear of brush reaches 1/4" long. Reinspection of brushes should not exceed 500 hours.

**⚠ CAUTION** Completely clean the old lubricant from the gear box before adding fresh lubricant. **UNDER NO CIRCUMSTANCES SHOULD DIFFERENT TYPES OF LUBRICANTS BE MIXED!**

## Lubrication

This unit is lubricated at the factory and should not require relubrication under normal running conditions.  
5 oz. 4ZF46

E  
N  
G  
L  
I  
S  
H

E  
S  
P  
A  
Ñ  
O  
L

F  
R  
A  
N  
Ç  
A  
I  
S

**For Repair Parts, call 1-800-323-0620**

**24 hours a day – 365 days a year**

Please provide the following information:

- Model number
- Serial number (if any)
- Part description and number as shown in parts list

**ENGLISH**

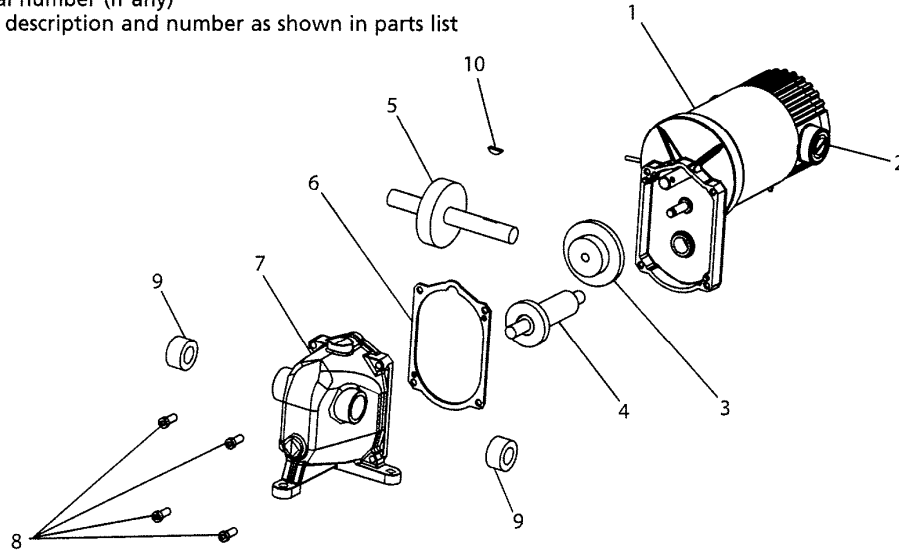

**Figure 1 – Repair Parts Illustration  
1LRA8, 1LRA9,  
1LRB1, 1LRB2, 1LRB3 and 1LRB4**

**Repair Parts List**

Ref No.	Description	1LRA8	1LRA9	1LRB1	Quantity
1	DC MOTOR	151-221-6003B	151-221-6003B	151-221-6003B	1
2	BRUSHES	158-200-9000	158-200-9000	158-200-9000	2
3	HIGH SPEED SUB-ASSY	146-060-0070	146-060-0038	146-060-0167	1
4	INTERM. HIGH SUB-ASSY	148-060-0525	148-060-0275	148-060-0167	1
5	LOW SPEED SUB-ASSY	147-060-0030	147-060-0030	147-060-0004	1
6	GASKET	127-060-1000	127-060-1000	127-060-1000	1
7	HOUSING SUB-ASSY	101-060-0900	101-060-0900	101-060-0900	1
8	HOUSING SCREWS	877-290-5163	877-290-5163	877-290-5163	4
9	SPACER	109-060-1000	109-060-1000	109-060-1000	2
10	KEY	130-200-0404	130-200-0404	130-200-0404	1
Δ	OUTPUT SEAL	902-081-2221	902-081-2221	902-081-2221	1

Ref No.	Description	1LRB2	1LRB3	1LRB4	Quantity
1	DC MOTOR	151-221-6003B	151-221-5003B	151-221-6003B	1
2	BRUSHES	158-200-9000	158-200-9000	158-200-9000	2
3	HIGH SPEED SUB-ASSY	146-060-0070	146-060-0038	146-060-0038	1
4	INTERM. HIGH SUB-ASSY	148-060-0070	148-060-0038	148-060-0038	1
5	LOW SPEED SUB-ASSY	147-060-0004	147-060-0004	147-060-0004	1
6	GASKET	127-060-1000	127-060-1000	127-060-1000	1
7	HOUSING SUB-ASSY	101-060-0900	101-060-0900	101-060-0900	1
8	HOUSING SCREWS	877-290-5163	877-290-5163	877-290-5163	4
9	SPACER	109-060-1000	109-060-1000	109-060-1000	2
10	KEY	130-200-0404	130-200-0404	130-200-0404	1
Δ	OUTPUT SEAL	902-081-2221	902-081-2221	902-081-2221	1

(Δ) NOT SHOWN.







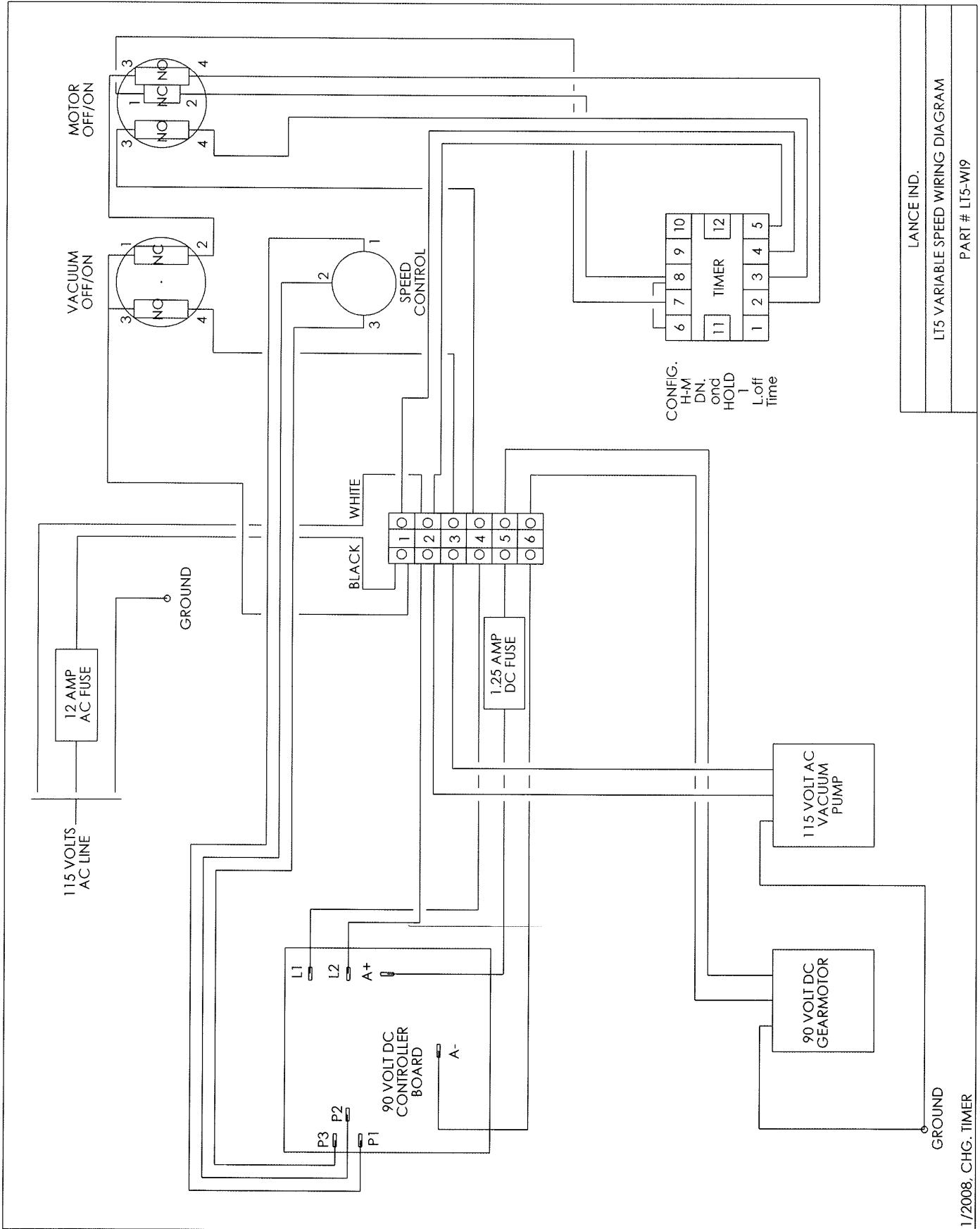

CONFIG.  
 H-M  
 DN.  
 on  
 HOLD  
 L-off  
 time

6	7	8	9	10
11	TIMER	12		
1	2	3	4	5

LANCE IND.  
 LT5 VARIABLE SPEED WIRING DIAGRAM  
 PART # LT5-W19